

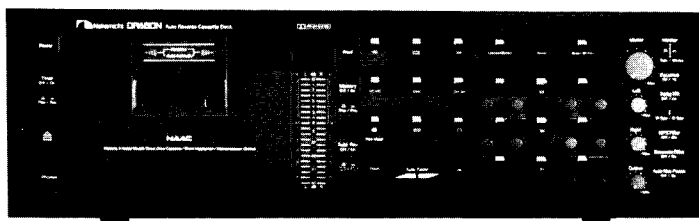

Service Manual

Nakamichi DRAGON

Auto Reverse Cassette Deck



CONTENTS

1.	General	2
2.	Mechanical Adjustments	2
2. 1.	Mechanism Control Cam Adjustment	2
2. 2.	Reel Motor Speed Adjustment in Play Mode	2
2. 3.	Record Head and Playback Head Tilt Adjustment	2
2. 4.	Head Base Stroke Adjustment	3
2. 5.	Erase Head Stroke Adjustment and Tape Guide Height Check	4
2. 6.	Erase Head Height and Tilt Adjustment	4
2. 7.	Back Tension Adjustment	5
2. 8.	Playback Head and Record Head Height Adjustment and Azimuth Alignment	5
2. 9.	Record Head Stroke Adjustment	6
2. 10.	Tape Travelling Adjustment	7
2. 11.	Flywheel Ass'y Height Adjustment	7
2. 12.	Lubrication	7
3.	Parts Location for Electrical Adjustment	8
4.	Electrical Adjustments and Measurements	9
4. 1.	Adjustment and Measurement Instructions	9
4. 2.	Frequency Response Adjustment	12
4. 3.	Dolby NR Circuit Check	13
5.	Mechanism Ass'y and Parts List	14
5. 1.	Synthesis	14
5. 2.	Cassette Lid Ass'y (A01)	15
5. 3.	Chassis Ass'y (A02)	15
5. 4.	Rear Panel Ass'y (B01)	16
5. 5.	Mechanism Ass'y (B02)	17
5. 6.	Flywheel Holder Ass'y (C01)	17
5. 7.	Sub Mechanism Chassis Ass'y (C02)	18
5. 8.	Main Mechanism Chassis Ass'y (C03)	19
5. 9.	Head Mount Base Ass'y (D01)	20
5. 10.	Supply Pressure Roller Ass'y (D02)	20
5. 11.	Take-up Pressure Roller Ass'y (D03)	20
5. 12.	Head Base Ass'y (D04)	20
5. 13.	Cassette Case Holder L Ass'y (D05)	20
5. 14.	Cassette Case Holder R Ass'y (D06)	21
5. 15.	Auto Shut-off Ass'y (D07)	21
5. 16.	Pneumatic Damper Ass'y (D08)	21
5. 17.	PA-1L Playback Head Ass'y (E01)	21
5. 18.	R-8L Record Head Ass'y (E02)	21
6.	Mounting Diagrams and Parts List	22
6. 1.	Power Switch P.C.B. Ass'y	22
6. 2.	Fuse P.C.B. Ass'y	22
6. 3.	Shut-off P.C.B. Ass'y	22
6. 4.	Counter Pulse Generator P.C.B. Ass'y	22
6. 5.	Direction P.C.B. Ass'y	23
6. 6.	Timer Switch P.C.B. Ass'y	23
6. 7.	Tape Select P.C.B. Ass'y	23
6. 8.	Volume P.C.B. Ass'y	23
6. 9.	Counter P.C.B. Ass'y	23
6. 10.	Indicator P.C.B. Ass'y	24
6. 11.	Switch P.C.B. Ass'y	24
6. 12.	Control P.C.B. Ass'y	25
6. 13.	Motor Control P.C.B. Ass'y	25
6. 14.	Logic P.C.B. Ass'y	28
6. 15.	Auto Azimuth P.C.B. Ass'y	29
6. 16.	Main P.C.B. Ass'y	32
7.	Schematic Diagrams	33
7. 1.	Attention to Servicemen	33
7. 2.	IC Block Diagrams	34
7. 3.	Amplifier Section	36
7. 4.	Auto Azimuth Control Section	37
7. 5.	Mechanism Control Section	38
8.	Wiring Diagram	39
9.	Timing Chart and Eq. Amp. Frequency Response	39
10.	Block Diagrams	40
11.	Specifications	42

1. GENERAL

1.1. Voltage Selector

Voltage selector is installed on the rear panel for Other version of the Nakamichi DRAGON. This voltage selector can select either 120 V or 220-240 V at customer's disposal.

1.2. Parts List for Carton and Packing

Part No.	Description	Q'ty
0F03685B	Inner Carton	1
0F03686B	Outer Carton	1
0F03629B	Packing	2

2. MECHANICAL ADJUSTMENTS

2.1. Mechanism Control Cam Adjustment

Before adjustment, remove the Front Panel Ass'y and the Cover Plate.

(1) Offset Adjustment of Control Motor Driver

(a) Refer to Fig. 2.1.

Adjust VR604 and VR603 on the Logic P.C.B. Ass'y to locate approximately at the middle of the variable range. Then turn ON the Power switch.

VR604 (for Cam position stop)

VR603 (for Cam position play)

(b) Press the Stop button to set the cassette deck in Stop mode. Adjust VR604 (for stop) so that the "S" mark on the Cam corresponds to the pointer on the mechanism chassis.

(c) Press the Play button to set the cassette deck in Playback mode. (Cam will rotate, and the position marked with "PY" comes to the pointer.) Adjust VR603 (for play) so that the "PY" mark on the Cam corresponds to the pointer.

(d) Repeat above (b) and (c) 2 - 3 times so that the "S" and "PY" marks on the Cam correspond to the pointer accurately in Stop and Playback modes respectively. (This adjustment is required because the position adjusted by one volume will be slightly changed when the other volume is adjusted.)

(e) Set the cassette deck in F.F., Pause, or Cue mode by pressing each button. Check to insure that the pointer is in a range of "F", "PS", "CU" mark respectively.

(f) If out of the range, precise adjustment for each position according to "(2) Offset Fine Adjustment of Control Motor Driver" will be required.

(2) Offset Fine Adjustment of Control Motor Driver

Adjust only if a satisfactory result is not obtained in "(1) Offset Adjustment of Control Motor Driver". This adjustment is made by changing the value of the fixed resistors on the Logic P.C.B. Ass'y. Note: The value of voltage is typical value.

(a) Observation Point of Reference Voltage

Observe the each voltage at the sliding contact of the Cam Control Volume VR605 (10 kΩ) in Stop, Fast (F.F. or Rew.), Pause and Playback modes.

(b) Reference Voltage

Reference voltage at the sliding contact of VR605 (Cam Control Volume) in each mode is as follows:

Mode	Reference Voltage (Typical Value)
Stop	0 V
Fast (F.F./Rew.)	-2.0 V
Pause	-6.5 V
Play	-9.1 V

— 2.0 V ± 0.25 V
— 2.6 V ± 0.4 V

(c) Resistors for Adjustment

Mode	Ref. No.	Typical Value
Fast (F.F./Rew.)	R640	22 kΩ
Pause	R643	76.8 kΩ (F)
Play	R639	10 kΩ

(d) Adjustment Procedures

- Set the cassette deck in Stop mode, then check to insure that the voltage at the sliding contact of VR605 is 0 V (± 0.3 V).
- Set the cassette deck in F.F. mode, then adjust the value of

R640 so that the voltage at the sliding contact of VR605 will become lower by 2.0 V (± 0.25 V) than in Stop mode.

- Press the Pause button to set the cassette deck in Pause mode. Adjust the value of R643 to obtain -6.5 V (± 0.4, -0.15 V) at the sliding contact of VR605.
- Set the cassette deck in Playback mode, then adjust the value of R639 so that the voltage at the sliding contact of VR605 will become lower by 2.6 V (± 0.4 V) than in Pause mode.

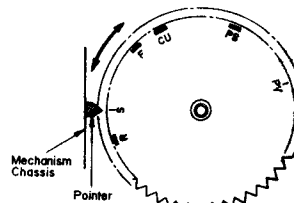

Fig. 2.1

2.2. Reel Motor Speed Adjustment in Play mode

- Connect a DC voltmeter to TP1 and GND on the Logic P.C.B. Ass'y.
- Without loading a cassette tape, set the cassette deck in Play mode.
- Adjust VR601 on the Logic P.C.B. Ass'y to obtain -4 V on the DC voltmeter.

2.3. Record Head and Playback Head Tilt Adjustment

Note: On items 2.3 - 2.9, refer to Fig. 2.2 flow chart. Refer to Figs. 2.3 and 2.4.

- Load a Tilt Check Gauge M-9039 (DA09039A) in the cassette deck.
- Clip the grounding terminal of the Tilt Check Gauge with one end of the cord with clip, and the chassis of the cassette deck with the other end.
- Remove both of the Height Gears.
- Set the cassette deck in Play mode. Check to insure whether the Beacons Playback Head "Upper" or "Lower" and Record Head "Upper" or "Lower" are illuminating. In order not to give damages onto the head surfaces, push both of slide knobs of the Gauge to the direction of arrow marks, then return them to the original place to be in contact with record head and playback head surfaces after Play mode is securely locked.
- Check to insure freedom from contact between the Gauge and pad lifter.
- Beacon Playback Head "Lower" will light on when height adjustment screw (P) turned clockwise but Playback Head "Upper" when counterclockwise. Adjust so that both "Upper" and "Lower" will light on even when you move the slide knob to the direction of an arrow mark and then return it to the original place.
- Same procedures will apply to the Beacons Record Head "Upper" and "Lower", except for the height adjustment screw (R).
- Set the cassette deck in Stop mode and fit both of the serrated Height Gears. Then set the cassette deck again in Play mode and insure all of the 4 Beacons are illuminating. If not, (3) through (7) will have to be repeated till satisfactory results are obtained.

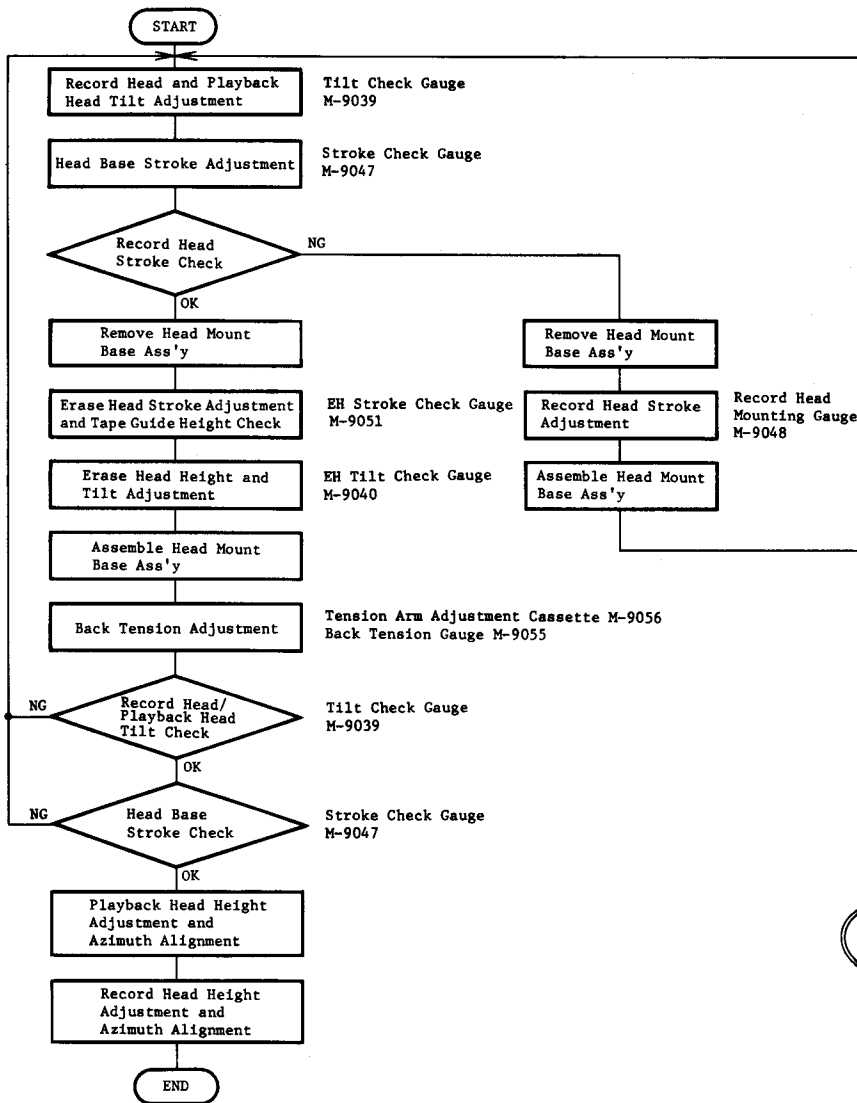

Fig. 2.2

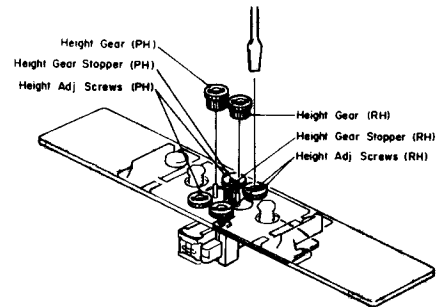

Fig. 2.3

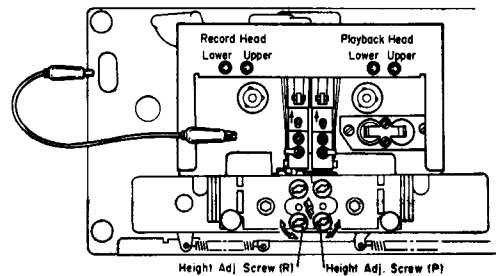

Fig. 2.4

2.4. Head Base Stroke Adjustment

Refer to Fig. 2.5.

Note: Before you conduct this adjustment, adjust with a "Tilt Check Gauge" to insure freedom from tilt on the playback head and record head.

- (1) Head Base Stroke Adjustment in Play Mode
- (a) Load a Stroke Check Gauge M-9047 (DA09047B) in the cassette deck.
- (b) Move Record Head Indicator and Playback Head Indicator to the direction of arrow mark "A" with your finger tip and then set the cassette deck in Play mode. Then slowly release the Indicators and insure whether each of the Indicators is in contact with record and playback heads.
- (c) Check to insure whether the "P" pointer on the Playback Head Indicator locates between the 2 lines on the Indicator Plate.
- (d) If the playback head stroke is noted to be misaligned, adjustment can be made by moving the stroke adjuster assembled in the head base assembly (either forwardly or backwardly).
- (e) Check to insure whether the "P" pointer on the Playback Head Indicator locates between the 2 lines on the Record Head Indicator, thus check can be made on record head stroke.

- (f) If the record head stroke is noted to be misaligned, adjustment can be made with a Record Head Mounting Gauge M-9048 (DA09048A).
- (2) Head Base Stroke Adjustment in Cue Mode
- (a) Load a Stroke Check Gauge M-9047 (DA09047B) in the cassette deck.
- (b) Move Record Head Indicator and Playback Head Indicator to the direction of arrow mark "A" with your finger tip and then set the cassette deck in Cue mode. Then slowly release the Indicators and insure whether each of the Indicators is in contact with record and playback heads.
- (c) Check to insure whether the "C" pointer on the Playback Head Indicator locates between the 2 lines on the Indicator Plate.
- (d) If the playback head stroke is noted to be misaligned, adjust VR602 on the Logic P.C.B. Ass'y till satisfactory results are obtained.
- (e) After completion of the Head Base Stroke Adjustment, check to insure accuracy of the Head Base Stroke Adjustment in Play mode. If the above are inaccurate, items (1) and (2) will have to be repeated till satisfactory results are obtained.

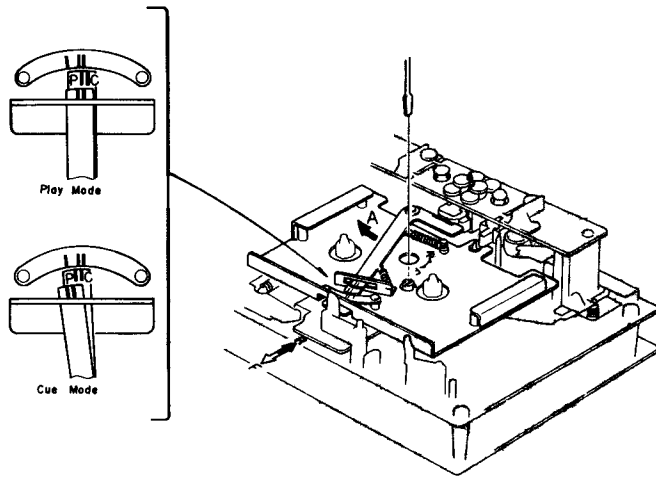

Fig. 2.5

2.5. Erase Head Stroke Adjustment and Tape Guide Height Check
Remove the Head Mount Base Ass'y.
Refer to Figs. 2.6 and 2.7.

- (1) Erase Head Stroke Adjustment
 - (a) Load an EH Stroke Check Gauge M-9051 (DA09051A) in the cassette deck.
 - (b) Set the cassette deck in Play mode, thus check can be made on erase head stroke through the EH Stroke Indicator.
 - (c) Check to insure whether the erase head surface is aligned with red line on the EH Stroke Indicator. If not, adjust the erase head stroke by loosening 2 screws A that assemble erase head and erase head plate.
 - (d) After completion of adjustment, 2 pcs. of screws shall be locked with lock tight paint.
- (2) Supply Tape Guide Height Check
 - (a) Load an EH Stroke Check Gauge M-9051 (DA09051A) in the cassette deck.
 - (b) Set the cassette deck in Play mode.
 - (c) Slide the Supply Tape Guide Check Bar down against the supply tape guide, and check to insure that the Supply Tape Guide Check Bar is accepted by the supply tape guide.
- (3) Take-up Tape Guide Height Check
 - (a) Load an EH Stroke Check Gauge M-9051 (DA09051A) in the cassette deck.
 - (b) Set the cassette deck in Play mode.
 - (c) Slide the Take-up Tape Guide Check Bar down against the take-up tape guide, and check to insure that the Take-up Tape Guide Check Bar is accepted by the take-up tape guide.

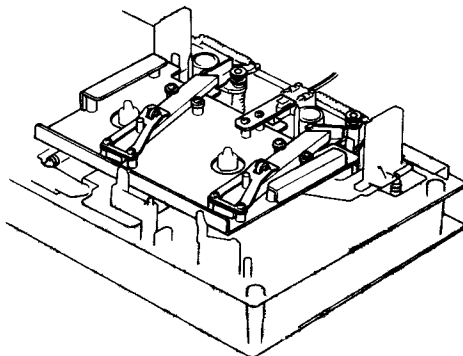

Fig. 2.6

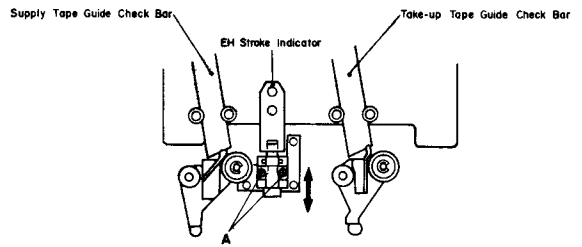

Fig. 2.7

2.6. Erase Head Height and Tilt Adjustment
Refer to Figs. 2.8 and 2.9.

- (1) Remove Head Mount Base Ass'y.
- (2) Load an EH Tilt Check Gauge M-9040 (DA09040A) in the cassette deck.
- (3) Set the cassette deck in Stop mode.
- (4) Check to insure whether one of the 3 Beacons is illuminating. Look down the mirror as shown by an arrow mark and slowly turn the Screw "Height" counterclockwise (or clockwise) so that the two horizontal lines on the mirror will become superposed on the line (in different color) of the erase head, and check to insure whether Beacon "1" is illuminating.
- (5) Turn Screw "Tilt" counterclockwise (or clockwise) to light on Beacon "2". Excessive turning will cause the Beacon "1" to light off. Adjustments of Screw "Tilt" will therefore be conducted till both of the Beacons "1" and "2" illuminate.
- (6) Turn Screw "Azimuth" counterclockwise (or clockwise) to light on Beacon "3". Excessive turning will cause either Beacon "1" or "2" to light off, and therefore adjust Screw "Azimuth" until all of the 3 Beacons "1", "2" and "3" illuminate.
- (7) Check to insure whether the horizontal line on the mirror corresponds to that on the erase head. If not, (4) through (7) will have to be repeated till satisfactory results are obtained.
- (8) After completion of adjustment, 3 pcs. of screws shall be locked with lock tight paint.

Note: Before use of this gauge, check to insure freedom from dust or dirt, or overflow in the groove of the erase head surface.

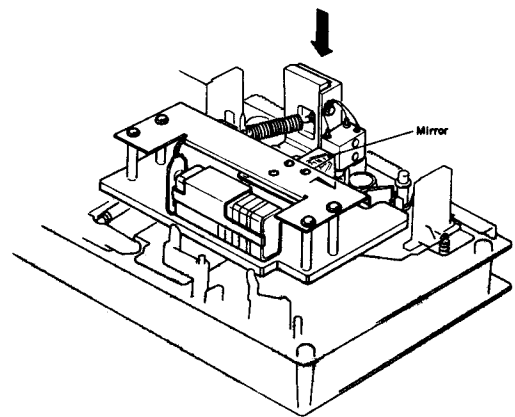

Fig. 2.8

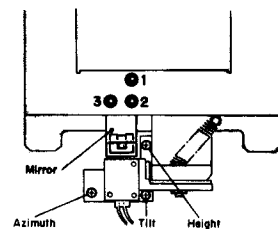

Fig. 2.9

2.7. Back Tension Adjustment

Refer to Figs. 2.10 – 2.13.

- (1) Load a Tension Arm Adjustment Cassette (DA09056A) in the cassette deck referring to Fig. 2.10.
- (2) Set the cassette deck in Play mode.
- (3) Bend the Back Tension Arm with pliers so that the gap between the Cassette Holding Spring assembled on the Head Base Ass'y and the Back Tension Arm becomes 0.5 mm as shown in Fig. 2.11. Do not bend the top of the Back Tension Arm.
- (4) Set the cassette deck in Stop mode, and remove the Tension Arm Adjustment Cassette (DA09056A), then set the cassette deck in Cue mode.

In Cue mode, check to insure that the gap is found between the Supply Reel Hub B Ass'y and the Felt of Back Tension Ass'y as shown in Fig. 2.12.

- (5) Load the Back Tension Gauge (DA09055A) in the cassette deck.
- (6) Set the cassette deck in Play mode and read the torque value of Back Tension Gauge.

If the value is in a range of 6 g-cm to 10 g-cm, adjustment is not necessary. If not, change the installation point of the Back Tension Spring as shown in Fig. 2.13, and obtain the torque of 7 g-cm to 9 g-cm range.

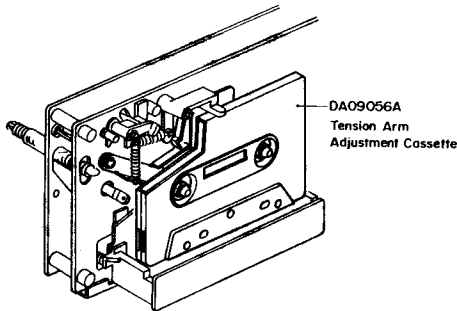

Fig. 2.10

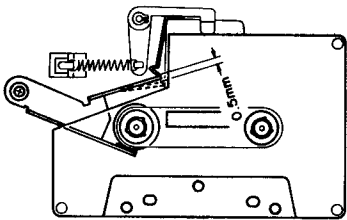

Fig. 2.11

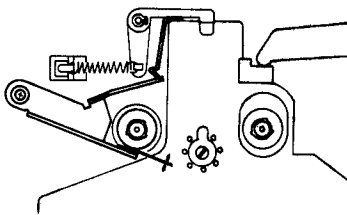

Fig. 2.12

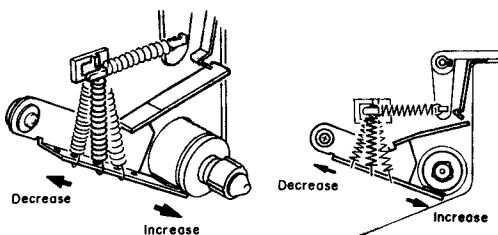

Fig. 2.13

2.8. Playback Head and Record Head Height Adjustment and Azimuth Alignment

Refer to Figs. 2.14 and 2.15. Perform the following adjustments successively.

(1) Playback Head Height Adjustment

- (a) Set the Monitor switch to Tape, Tape Selector button to ZX and Eq. switch to 70 μ s.
- (b) Connect a VTVM to Output Jacks.
- (c) Load a 1 kHz Track Alignment Tape (DA09007B) and set the cassette deck in Forward-Play mode.
- (d) Turn the PH Height Gear until the outputs of both channels become minimum on the VTVM.

(2) Azimuth Reference Position Adjustment

- (a) With the Cassette Holder open, press the Forward-Play button. Adjust VR824 on the Auto Azimuth P.C.B. Ass'y so that the Alignment Indicator coincides with the Pointer in the Azimuth Alignment Motor Ass'y. Refer to Fig. 2.15.
- (b) With the Cassette Holder open, press the Reverse-Play button. Adjust VR823 on the Auto Azimuth P.C.B. Ass'y so that the Alignment Indicator coincides with the Pointer in the Azimuth Alignment Motor Ass'y.

(3) Playback Head Azimuth Alignment

- (a) Disconnect the Azimuth Motor by pulling out the connector CN-5 of the Auto Azimuth P.C.B. Ass'y.
- (b) Load a 15 kHz Azimuth Alignment Tape (DA09004B) and set the cassette deck in Forward-Play mode.
- (c) Turn the PH Azimuth Alignment screw until the outputs of both channels become maximum on the VTVM.

(4) Phase Adjustment and Record Head Height Adjustment and Azimuth Alignment

- (a) Connect a DC millivoltmeter to pin 1 of CN-5 on the Auto Azimuth P.C.B. Ass'y (CN-5 is removed).
- (b) Load a 15 kHz Azimuth Alignment Tape (DA09004B) and set the cassette deck in Forward-Play mode. Adjust the VR701 on the Main P.C.B. Ass'y to obtain 0 V on the DC millivoltmeter. (Adjustment should be carried out within approx. 10 seconds.)
- (c) Turn the Azimuth Alignment Tape upside down and set the cassette deck in Reverse-Play mode. Adjust VR702 on the Main P.C.B. Ass'y to obtain 0 V on the DC millivoltmeter within approx. 10 seconds.
- (d) Load a Reference ZX Tape (DA09037B) and set the cassette deck in Rec./Forward-Play mode.
- (e) Press the Level Calibration button to oscillate 400 Hz (0 dB) and turn the RH Height Gear until the outputs of both channels become maximum on the VTVM.
- (f) Press the Bias Calibration button to oscillate 15 kHz (-20 dB) and turn the RH Azimuth Alignment Screw until the outputs of both channels become maximum on the VTVM.
- (g) Feed in 5 kHz (-20 dB) from an external generator. Set the cassette deck in Rec./Forward-Play mode and adjust VR822 on the Auto Azimuth P.C.B. Ass'y to obtain the closest value to 0 V on the DC millivoltmeter at pin 1 of CN-5. (Adjustment should be done within approx. 10 seconds.)
- (h) Mount CN-5 on the original place.
- (i) Load a 15 kHz Azimuth Alignment Tape (DA09004B) and set the cassette deck in Forward-Play mode. Note the Indicator swing from the Pointer. Turn the Azimuth Alignment Tape upside down, set the cassette deck in Reverse-Play mode and note the Indicator swing from the Pointer. (Indicator will move in the opposite direction as above.) Adjust the PH Azimuth Alignment Screw so that the Pointer swings evenly in Forward-Play and Reverse-Play modes.
- (j) Load a 15 kHz Azimuth Alignment Tape (DA09004B) and set the cassette deck in Forward-Play mode. Pull out CN-5 of the Auto Azimuth P.C.B. Ass'y after the Direction Indicator has been finished flashing.
- (k) Press the Bias Calibration button to oscillate 15 kHz (-20 dB) and turn the RH Azimuth Alignment Screw until the outputs of both channels become maximum on the VTVM.
- (l) Mount CN-5 on the original place.

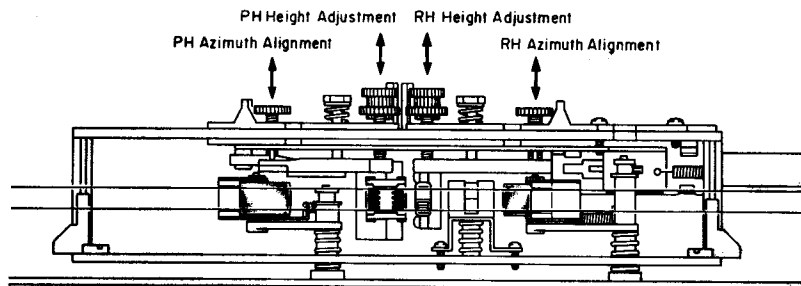

Fig. 2.14

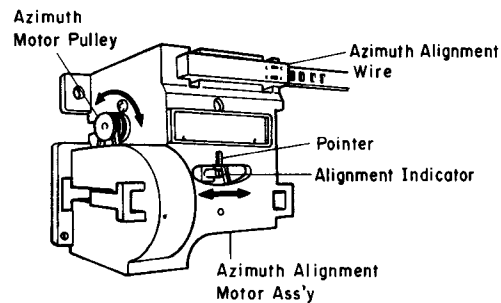

Fig. 2.15

2.9. Record Head Stroke Adjustment

Refer to Figs. 2.16 and 2.17.

Note: This adjustment will be required only to insure freedom from misalignment of the record head stroke in the record head stroke check mode.

- (1) Check the accuracy of the record head stroke.
- (2) Remove Head Mount Base Ass'y.
- (3) Remove the record head assembly.
- (4) Adjustment of Record Head Mounting Gauge M-9048 (DA0-9048A)
 - (a) Mount the Block B onto the Mounting Gauge Plate.
 - (b) Loosen the 2 screws fixing the Block A.
 - (c) As shown in Fig. 2.16, hold the Gauges (3.05 mm and 0.1 mm thickness) between the Block A and Block B, and fix the Block A with screws, pushing the Block A to the 2 guide pins.
- (5) Remove the Block B from the Mounting Gauge Plate.
- (6) As shown in Fig. 2.17, mount the R-8L record head assembly onto the Mounting Gauge Plate, then check the location of the R-8L record head surface. (If record head touches the Block C, loosen 2 pcs. of screws that assemble record head and record head plate, then place the R-8L record head assembly onto the Plate.)
- (7) Remove the R-8L record head assembly from the Mounting Gauge Plate.
- (8) Readjustment of Record Head Mounting Gauge M-9048 (DA09048A)
 - (a) Mount the Block B onto the Mounting Gauge Plate.
 - (b) Loosen the 2 screws fixing the Block A.
 - (c) As shown in Fig. 2.16, hold the Gauges (3.05 mm and either one of 0.05, 0.15, 0.2, 0.25, 0.3 or 0.35 mm thickness) between the Block A and Block B, and fix the Block A with screws, pushing the Block A to the 2 guide pins.
- (9) Remove the Block B from the Mounting Gauge Plate.
- (10) Mount the R-8L record head assembly onto the Mounting Gauge Plate.
- (11) As shown in Fig. 2.17, loosen 2 pcs. of screws that assemble record head and record head plate. As the location of the Block A is secured by the item (8)-(c), push the record head to the directions A and B, then tighten 2 pcs. of screws.
- (12) Check to insure freedom from gap between the Block C and record head surface, then tighten the 2 pcs. of screws on the record head assembly with lock tight paint.
- (13) Remove the R-8L record head assembly from the Mounting Gauge Plate.
- (14) Assemble the record head assembly to the head mount base assembly.
- (15) Assemble the head mount base assembly to the mechanism assembly.
- (16) Check the record head stroke. If the above are inaccurate, items (1) through (16) will have to be repeated till satisfactory results are obtained.

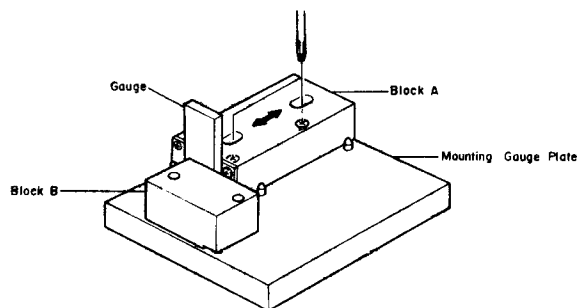
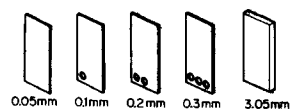

Fig. 2.16

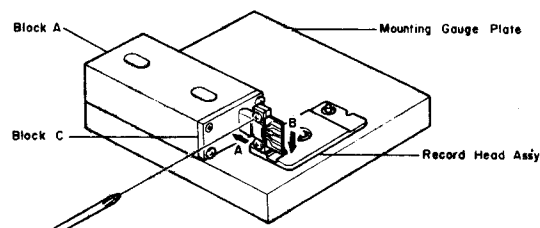

Fig. 2.17

2.10. Tape Travelling Adjustment

The adjustment shall be made with a modified version of the current type EXII C-90 as shown in Fig. 2.18 (error will be made if a current type Tape Travelling Cassette (DA09011A) should be used for this purpose).

While modifying an EXII C-90, the tape guides in the cassette housing shall be kept protected to avoid tilt.

Check shall be made in the following procedures.

- (1) An EXII C-90 tape thus modified shall be loaded onto the cassette deck.
- (2) Release the back-tension (rotate the Supply Reel and feed out some length of tape) and set the cassette deck in Play mode.
- (3) In this juncture, check to insure whether the tape is free from waving or slippage from the tape guide.
- (4) When the modified EXII C-90 is played back, check to insure whether the tape is freedom from waving from head surface or at pressure rollers.
- (5) If either of waving or slippage from the tape guide should be noted, adjustments of items 2.3 to 2.9, etc. will be required.

As a case may be, the said waving or slippage may have been caused from defective Supply Pressure Roller Ass'y or Take-up Pressure Roller Ass'y without parallel contact with capstans. If such are noted, the Pressure Roller Assemblies will have to be replaced.

Further, excessively weak take-up torque or strong take-up torque may cause defective tape travelling.

The cassette deck is intended to be an adjustment-free model, however if the similar matters as above should be noted, please replace the Reel Hub Ass'y to obtain appropriate take-up torque.

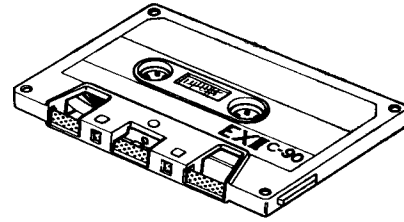

Fig. 2.18

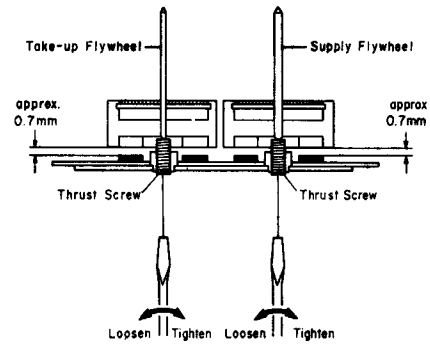

Fig. 2.19

2.11. Flywheel Ass'y Height Adjustment

Refer to Fig. 2.19.

- (1) Adjust both Thrust Screws so that the gaps between the Motor Coil Assemblies and the Flywheel Assemblies become approx. 0.7 mm.
- (2) Connect a synchroscope to CN501-1 (take-up side) and CN502-1 (supply side) on the Motor Control P.C.B. Ass'y. Set the synchroscope to AC input.
- (3) Check to insure that the peak-to-peak levels of both waveforms are greater than 20 mV.
- (4) Apply a quantity of lock tight paint to the Thrust Screws.

Note: Mount washers on the Flywheel Ass'y as follows if Flywheel Ass'y is replaced.

- (a) Turn the Thrust Screw so that the gap between the Motor Coil Ass'y and the Flywheel Ass'y becomes approx. 1 mm.
- (b) From the front side of the cassette deck, first insert a Washer 3.1 mm FT into the capstan shaft of supply side (Washer 2.6 mm FT for take-up side), then insert a Washer 3 mm (Washer 2.5 mm) into the shaft and press it until the Washer 3.1 mm FT (Washer 2.6 mm FT) contacts with the flange sufficiently. Refer to Fig. 5.5.
- (c) Perform the "Flywheel Ass'y Height Adjustment" in item 2.11.

2.12. Lubrication

This is a lubrication-free cassette deck except when parts are replaced. Apply the following lubricant for each replaced part:

- (1) LAUNA #100
Capstan Shaft
Pressure Roller Shaft
Thrust Cap
- (2) FLOIL GB-TS-1
Reel Hub Shaft
Thrust portion on the Capstan Shaft
FLOIL GB-TS-1, made by Kanto Chemicals Co., Ltd. in Japan.
We suggest that you use the above or equivalent type. If unavailable please contact Kanto Chemicals Co., Ltd., 2-7 Kanda Suda-cho Chiyoda-ku, Tokyo 101 Japan.
- (3) Silicon Oil #3000 CST
Air Damper Piston

Note: Excessive lubrication may cause defective damper action as the 0.2 ϕ hole at the end of the cylinder may be filled with oil.

4. ELECTRICAL ADJUSTMENTS AND MEASUREMENTS

Note: Electrical adjustment should be performed after mechanical adjustment is completed.

4.1. Adjustment and Measurement Instructions

STEP	ITEM	SIGNAL SOURCE	OUTPUT CONNECTION	MODE	ADJUSTMENT	REMARKS
1	Tone Level Calibration	Tone 400 Hz and 15 kHz	VTVM to TP101, TP201 on Main P.C.B. and Output Jacks	Tone — 400 Hz/15 kHz Monitor SW — Source	Auto Azimuth P.C.B. VR721 (400 Hz) VR722 (15 kHz) Main P.C.B. VR301 (400 Hz Balance)	<ol style="list-style-type: none"> 1. Press the Level Calibration button to oscillate 400 Hz. 2. Adjust VR721 to obtain 350 mV on the VTVM at TP101 (L ch). 3. Adjust VR301 to obtain the same level as L ch at TP201. 4. Measure the reading on the VTVM at the Output Jacks. 5. Press the Bias Calibration button to oscillate 15 kHz. 6. Adjust VR722 to obtain 20 dB lower level than in 4 on the VTVM at the Output Jacks. 7. Press the Calibration Reset button to stop the tone oscillation.
2	Meter Level Calibration	400 Hz to Input Jacks and Tone 400 Hz and 15 kHz	VTVM to TP101, TP201 on Main P.C.B.	Tone — OFF/400 Hz/15 kHz Monitor SW — Source	Auto Azimuth P.C.B. VR701, VR801 VR702, VR802 VR703, VR803 VR721 (400 Hz) VR722 (15 kHz)	<ol style="list-style-type: none"> 1. Feed in 400 Hz, then adjust the Input level controls to obtain 350 mV —0.9 dB on the VTVM. 2. Adjust VR701 (VR801) so that the 0 dB segment of the level meter starts illuminating. 3. Press the Level Calibration button to oscillate 400 Hz, then adjust VR721 to obtain 350 mV —0.25 dB on the VTVM. 4. Adjust VR702 (VR802) so that the 0 dB segment of the level meter starts illuminating. 5. Press the Bias Calibration button to oscillate 15 kHz, then adjust VR722 to obtain 35 mV —0.25 dB on the VTVM. 6. Adjust VR703 (VR803) so that the 0 dB segment of the level meter starts illuminating. 7. Press the Calibration Reset button. 8. Re-adjust the tone level according to step 1 "Tone Level Calibration".
3	MPX Filter Adjustment	19 kHz \pm 100 Hz to Input Jacks	VTVM to Output Jacks	Monitor SW — Source Dolby NR SW — OFF MPX SW — ON	Main P.C.B. L102, L202	<ol style="list-style-type: none"> 1. Turn the Output level control fully clockwise (maximum position). 2. Adjust the Input Level controls to obtain 1 V on the VTVM. 3. Set the MPX Filter switch to ON, then adjust L102 (L202) to obtain the minimum reading on the VTVM (the minimum reading will be less than —30 dB).
4	Playback Head and Record Head Height Adjustment and Azimuth Alignment	1 kHz Track Alignment Tape (DA09007B) 15 kHz Azimuth Tape (DA09004B) 5 kHz (—20 dB) to Input Jacks Tone 15 kHz	VTVM to Output Jacks and DC Millivoltmeter to pin 1 of CN-5 on Auto Azimuth P.C.B.	Playback (Fwd./Rev.) Record, Playback (Fwd.) Monitor SW — Tape Tape SW — ZX Eq. SW — 70 μ s Dolby NR SW — OFF MPX SW — OFF	PH Height Gear PH Azimuth Alignment Screw RH Height Gear RH Azimuth Alignment Screw Auto Azimuth P.C.B. (Fwd. Azimuth Ref.) VR824 (Rev. Azimuth Ref.) VR823 (5 kHz Phase) VR822 Main P.C.B. (15 kHz Fwd. Phase) VR701 (15 kHz Rev. Phase) VR702	<p>Perform the following adjustments successively.</p> <ol style="list-style-type: none"> 1. Playback Head Height Adjustment <ol style="list-style-type: none"> a. Load a 1 kHz track alignment tape (DA09007B) and forward-play it back. b. Adjust the PH Height Gear to obtain minimum readings of both channels on the VTVM. 2. Azimuth Reference Position Adjustment <ol style="list-style-type: none"> a. With the Cassette Holder open, press the Forward-Play button. Adjust VR824 on the Auto Azimuth P.C.B. Ass'y so that the Alignment Indicator coincides with the Pointer in the Azimuth Alignment Motor Ass'y. Refer to Fig. 2.15. b. With the Cassette Holder open, press the Reverse-Play button. Adjust VR823 on the Auto Azimuth P.C.B. Ass'y so that the Alignment Indicator coincides with the Pointer in the Azimuth Alignment Motor Ass'y. 3. Playback Head Azimuth Alignment <ol style="list-style-type: none"> a. Disconnect the Azimuth Motor by pulling out the connector CN-5 of the Auto Azimuth P.C.B. Ass'y. b. Load a 15 kHz azimuth tape (DA09004B) and forward-play it back. c. Adjust the PH Azimuth Alignment Screw to obtain maximum readings of both channels on the VTVM. 4. Phase Adjustment and Record Head Height Adjustment and Azimuth Alignment <ol style="list-style-type: none"> a. Disconnect CN-5 of the Auto Azimuth P.C.B. Ass'y. b. Load a 15 kHz azimuth tape (DA09004B) and forward-play it back. Adjust VR701 on the Main P.C.B. Ass'y to obtain 0 V on the DC millivoltmeter. (Adjustment should be carried out within approx. 10 seconds.) (to be continued)

STEP	ITEM	SIGNAL SOURCE	OUTPUT CONNECTION	MODE	ADJUSTMENT	REMARKS
4	(continued)					<p>c. Turn the azimuth tape upside down and reverse-play it back. Adjust VR702 on the Main P.C.B. Ass'y to obtain 0 V on the DC millivoltmeter within approx. 10 seconds.</p> <p>d. Load a reference ZX tape (DA09037B) and record/forward-play it back.</p> <p>e. Press the Level Calibration button to oscillate 400 Hz (0 dB) and adjust the RH Height Gear to obtain maximum readings of both channels on the VTVM.</p> <p>f. Press the Bias Calibration button to oscillate 15 kHz (-20 dB) and adjust the RH Azimuth Alignment Screw to obtain maximum readings of both channels on the VTVM.</p> <p>g. Feed in 5 kHz (-20 dB) from an external generator and record/forward-play it back. Adjust VR822 on the Auto Azimuth P.C.B. Ass'y to obtain the closest value to 0 V on the DC millivoltmeter. (Adjustment should be done within approx. 10 seconds.)</p> <p>h. Mount CN-5 on the original place.</p> <p>i. Load a 15 kHz azimuth tape (DA09004B) and forward-play it back. Note the Indicator swing from the Pointer. Turn the azimuth tape upside down, reverse-play it back and note the Indicator swing from the Pointer. (Indicator will move in the opposite direction as above.) Adjust the PH Azimuth Alignment Screw so that the Pointer swings evenly in Forward-Play and Reverse-Play modes.</p> <p>j. Load a 15 kHz azimuth tape (DA09004B) and forward-play it back. Pull out CN-5 of the Auto Azimuth P.C.B. Ass'y after the Direction Indicator has been finished flashing.</p> <p>k. Press the Bias Calibration button to oscillate 15 kHz (-20 dB) and adjust the RH Azimuth Alignment Screw to obtain maximum readings of both channels on the VTVM.</p> <p>l. Mount CN-5 on the original place.</p>
5	Playback Level Calibration	400 Hz Level Tape (DA09005B)	VTVM to TP101, TP201 on Main P.C.B.	Playback (Fwd./Rev.) Monitor SW - Tape Eq. SW - 70 μ s Dolby NR SW - OFF MPX SW - OFF	Main P.C.B. VR501, VR601 (Fwd.) VR502, VR602 (Rev.)	<ol style="list-style-type: none"> Load a 400 Hz level tape and forward-play it back. Adjust VR501 (VR601) to obtain 350 mV on the VTVM. Turn the tape upside down and reverse-play it back. Adjust VR502 (VR602) to obtain 350 mV on the VTVM.
6	Playback Frequency Response Adjustment	400 Hz Level Tape (DA09005B) 10 kHz PB Frequency Response Tape (DA09003B) 15 kHz PB Frequency Response Tape (DA09002B) 20 kHz PB Frequency Response Tape (DA09001B)	VTVM to Output Jacks	Playback (Fwd./Rev.) Monitor SW - Tape Tape SW - SX Eq. SW - 70 μ s Dolby NR SW - OFF MPX SW - OFF	Main P.C.B. (Fwd.) R507, R607 R508, R608 (Rev.) R517, R617 R518, R618	<ol style="list-style-type: none"> Load a 400 Hz level tape and forward-play it back. Adjust the Output level control to a certain level (0 dB for example). Load 10 kHz, 15 kHz and 20 kHz PB frequency response tapes and forward-play them back. Short R507 (R607) or R508 (R608) to obtain the following levels against the level for the 400 Hz level tape. 10 kHz: -20 dB -1 dB to +2 dB 15 kHz: -20 dB -1 dB to +3 dB 20 kHz: -20 dB -1 dB to +4 dB Turn the tape upside down and reverse-play them back. Short R517 (R617) or R518 (R618) to obtain the levels which suffice the range specified in above 2. Refer to the "Playback Frequency Response Adjustment" in item 4.2 for the detailed description.
7	Bias Oscillation Frequency and Erase Current Adjustment		VTVM across the additional 0.1 Ω resistor and Frequency Counter to CN1-1 on Main P.C.B.	Record, Pause Monitor SW - Source Tape SW - ZX Eq. SW - 70 μ s Dolby NR SW - OFF MPX SW - OFF	Main P.C.B. T301 R313, R314	<ol style="list-style-type: none"> Connect an additional 0.1 Ω resistor in series to the Erase Head, then connect a VTVM across it. Adjust T301 to obtain 105 kHz on the frequency counter. Check the erase current by the VTVM. Erase current will be in a range of 310 mA to 400 mA (typically approx. 350 mA). If erase current is not sufficient, increase it by shorting R313 or R314. After completion of the erase current adjustment, re-check the bias oscillation frequency. Remove the additional 0.1 Ω resistor.

STEP	ITEM	SIGNAL SOURCE	OUTPUT CONNECTION	MODE	ADJUSTMENT	REMARKS
8	Record Amplifier Equalizer Adjustment	23 kHz (-20 dB) to Input Jacks	VTVM to TP102, TP202 on Main P.C.B.	Record, Pause Monitor SW - Source Tape SW - ZX Eq. SW - 70 μ s Dolby NR SW - OFF MPX SW - OFF	Main P.C.B. L503, L603	1. Remove the bias-cut jumper from the dip side of the Main P.C.B. Assy. 2. Adjust L503 (L603) to obtain approx. +16 dB at 23 kHz on the VTVM. 3. Re-solder the bias-cut jumper.
9	Bias Trap Adjustment (Record Amp.)	Remove input signals	VTVM to TP103, TP203 on Main P.C.B.	Same as above	Main P.C.B. L504, L604	Adjust L504 (L604) to obtain minimum reading on the VTVM.
10	Bias Trap Adjustment (Playback Amp.)	Remove input signals	VTVM to IC502-3, IC602-3 (Fwd. Playback Amp.), IC502-1, IC602-1 (Rev. Playback Amp.) and AM39 (Sub Playback Amp.)	Same as above	Main P.C.B. L501, L502 L601, L602 L701	1. Adjust L501 (L601) to obtain minimum reading on the VTVM at IC502-3 (IC602-3). 2. Adjust L502 (L602) to obtain minimum reading on the VTVM at IC502-1 (IC602-1). 3. Adjust L701 to obtain minimum reading on the VTVM at terminal AM39.
11	Record Level Calibration and Recording Bias Current Adjustment	Tone 400 Hz and 15 kHz and 10 kHz/20 kHz (-20 dB) to Input Jacks	VTVM and Distortion Meter to Output Jacks	Record, Playback (Fwd.) Tone - 400 Hz/ 15 kHz Monitor SW - Tape Tape SW - ZX/SX EX Eq. SW - 70 μ s (ZX/SX) 120 μ s (EX) Dolby NR SW - C-Type/B-Type/ OFF MPX SW - OFF	Control P.C.B. (Level) ZX: VR101, VR201 SX: VR102, VR202 EX: VR103, VR203 (Bias) ZX: VR106, VR206 SX: VR105, VR205 EX: VR104, VR204	Adjustment should be made in the order of ZX, SX and EX. 1. Set the Dolby NR switch to C-Type. 2. Load a reference ZX tape (DA09037B), reference SX tape (DA09025B) and reference EXII tape (DA09066B). 3. Adjust the Sensitivity controls VR101 (VR201) for ZX, VR102 (VR202) for SX and VR103 (VR203) for EXII to maximum position. 4. Adjust the Bias controls VR106 (VR206) for ZX, VR105 (VR205) for SX and VR104 (VR204) for EXII to maximum position. 5. Press the Record and Fwd. Play buttons, then press the Level Calibration button to oscillate 400 Hz. 6. Adjust the Sensitivity controls VR101 (VR201), VR102 (VR202) and VR103 (VR203) to obtain 0 dB on the level meters. 7. Press the Bias Calibration button to oscillate 15 kHz. 8. Adjust the Bias controls VR106 (VR206), VR105 (VR205) and VR104 (VR204) to obtain 0 dB on the level meters. 9. Repeat 5 to 8 as above two or three times to obtain optimum performance. 10. Set the Dolby NR switch to B-Type/OFF. 11. Feed in 10 kHz (-20 dB) and 20 kHz (-20 dB), then record and forward-play them back. Check to insure that the levels are within -20 dB \pm 2 dB against the levels in Dolby NR C-Type. 12. Check to insure whether the total harmonic distortion is less than 0.8% for ZX tape and 1.0% for SX and EXII tapes.
12	Overall Frequency Response Adjustment	400 Hz (0 dB) and 20 Hz to 20 kHz (-20 dB) to Input Jacks	VTVM to Output Jacks	Record, Playback (Fwd.) Monitor SW - Source/ Tape Tape SW - ZX/SX/EX Eq. SW - 70 μ s (ZX/SX) 120 μ s (EX) Dolby NR SW - OFF MPX SW - OFF	Main P.C.B. L503, L603	1. Set the Monitor switch to Source. 2. Feed in 400 Hz (0 dB) and adjust the Input level controls to obtain 0 dB on the level meters. 3. Switch the Generator output level to -20 dB. 4. Set the Monitor switch to Tape, then record and forward-play it back. 5. Feed in 20 Hz to 20 kHz (-20 dB), and check to insure whether the output levels are within -20 dB \pm 3 dB. 6. If above is not sufficient, adjust L503 (L603) to obtain approx. -20 dB on the VTVM at 20 kHz. 7. Conduct step 11 "Record Level Calibration and Recording Bias Current Adjustment". 8. If above is not sufficient further, precise re-adjustment of step 6 "Playback Frequency Response", replacement of Playback Head or Record Head, check on item 2.10 "Tape Travelling Adjustment" or frequency response adjustment according to item 4.2 will be required.
13	Crosstalk Measurement	1 kHz to Input Jacks	1 kHz Band Pass Filter and VTVM to Output Jacks	Record and Playback (Fwd.) Monitor SW - Tape Tape SW - ZX Eq. SW - 70 μ s Dolby NR SW - OFF		1. Erase a reference ZX tape with a bulk eraser. 2. Load the reference tape and adjust the Input level controls to obtain 0 dB on the level meters. 3. Record input signals on the tape with pressing the Record and Fwd. Play buttons. 4. Press the Stop button, then reverse-play it back with pressing Rev. Play button. 5. Measure the difference between 3 and 4. (to be continued)

STEP	ITEM	SIGNAL SOURCE	OUTPUT CONNECTION	MODE	ADJUSTMENT	REMARKS
13 (continued)						6. Record input signals on the tape but not on the portion used as above. 7. Turn the tape the other way round and forward-play it back. 8. Measure the output level difference between 6 and 7.
14	Channel Separation Measurement	1 kHz to Input Jacks	1 kHz Band Pass Filter and VTVM to Output Jacks	Record and Playback (Fwd.) Monitor SW — Tape Tape SW — ZX Eq. SW — 70 μ s Dolby NR SW — OFF		1. Erase a reference ZX tape with a bulk eraser. 2. Load the reference tape and adjust the L ch (R ch) Input level control to obtain 0 dB on the level meter. Close the R ch (L ch) Input level control. 3. Record and forward-play the input signals and measure the R ch (L ch) level on the VTVM. 4. Turn the tape the other way round and reverse-play it back. 5. Measure the R ch (L ch) level on the VTVM.
15	Signal to Noise Ratio Measurement	400 Hz to Input Jacks	VTVM and Distortion Meter to Output Jacks	Record and Playback (Fwd.) Monitor SW — Tape Tape SW — ZX Eq. SW — 70 μ s Dolby NR SW — B-Type/C-Type		1. Feed in 400 Hz and record and forward-play it back. 2. Adjust the Input level controls to obtain a 3% total harmonic distortion in Playback mode. 3. Close the Input level controls, then record again. After rewind, forward-play back and check the output level difference between 3 and 4. Note: The filter of IHF-A curve shall be used in the measurements.
16	Total Harmonic Distortion Measurement	400 Hz to Input Jacks	Distortion Meter to Output Jacks	Record and Playback (Fwd.) Monitor SW — Tape Tape SW — ZX/SX/EX Eq. SW — 70 μ s (ZX/SX) 120 μ s (EX) Dolby NR SW — OFF		1. Adjust the Input level controls to obtain 0 dB on the level meters. 2. Record and forward-play it back. 3. Read the distortion meter and check to insure that the distortion is less than 0.8% for ZX tape and 1.0% for SX and EXII tapes.
17	Wow/Flutter & Speed Measurement	3 kHz Speed and Wow/Flutter Tape (DA09006C)	Wow/Flutter Meter to Output Jacks	Playback Monitor SW — Tape Eq. SW — 70 μ s		Forward-play back and read the wow/flutter meter.

4.2. Frequency Response Adjustment

(1) Playback Frequency Response Adjustment

Refer to Figs. 4.2.1 and 4.2.2.
Peaking adjustment will be required if playback level is not sufficient when 20 kHz PB frequency response tape is played back as referred to step 6 in 4.1 "Adjustment and Measurement Instructions".

The adjustment will compensate the gap loss of the playback head.

Peaking level is varied by the short circuit of the following resistors in the playback amp. circuit of the Main P.C.B. Ass'y.

Forward Playback Amp.:

R507, R607 (220 ohms) or R508, R608 (470 ohms)

Reverse Playback Amp.:

R517, R617 (220 ohms) or R518, R618 (470 ohms)

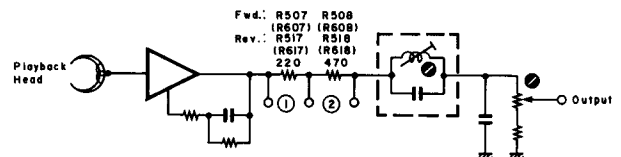

Fig. 4.2.1

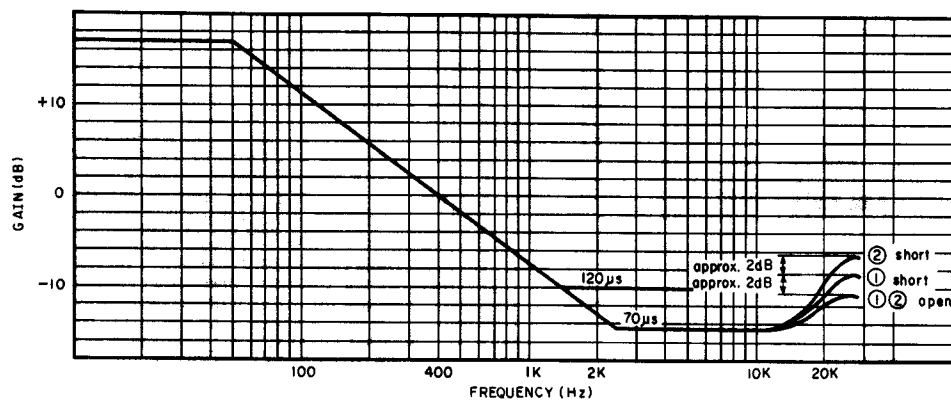

Fig. 4.2.2

(2) Record Current Frequency Response Adjustment

Record eq. peaking is adjusted for compensating the overall frequency response when playback frequency response is completed.

Normally however peaking frequency is pre-adjusted to approx. 23 kHz in Record mode. Refer to Fig. 4.2.3.

(a) For ZX Tape

1) Feed in 400 Hz (0 dB), then record and play it back. Adjust bias current by VR106 (VR206) on the Control P.C.B. Ass'y to obtain 0.8% distortion.

2) Feed in 10 kHz and 400 Hz (-20 dB), then record and play them back.

Check the difference of the levels between 10 kHz and 400 Hz, and mount an additional capacitor in parallel with C126 (C226) on the Main P.C.B. Ass'y from the dip side of the printed circuit board depending upon the difference of the levels against 400 Hz. Refer to Fig. 4.2.4.

Level Difference	Addition	Total
0 dB	0	820 pF
-1 dB	220 pF	1040 pF

3) Feed in 22 kHz (-20 dB), then record and play it back. Adjust record peaking coil L503 (L603) on the Main P.C.B. Ass'y to obtain flat overall frequency response.

(b) For SX Tape

1) Feed in 15 kHz and 400 Hz (-20 dB), then record and play them back.

Adjust bias current by VR105 (VR205) on the Control P.C.B. Ass'y to obtain flat overall frequency response.

2) Feed in 20 kHz and 400 Hz (-20 dB), then record and play them back.

And check to insure that the overall frequency response is flat.

(c) For EXII Tape

1) Feed in 15 kHz and 400 Hz (-20 dB), then record and play them back.

Adjust bias current by VR104 (VR204) on the Control P.C.B. Ass'y to obtain flat overall frequency response.

2) Feed in 20 kHz and 400 Hz (-20 dB), then record and play them back.

And check to insure that the overall frequency response is flat.

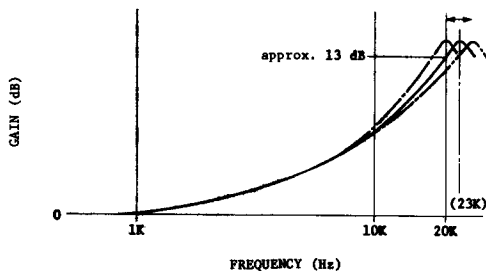

Fig. 4.2.3

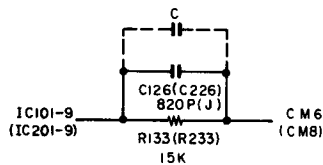

Fig. 4.2.4

4.3. Dolby NR Circuit Check

Dolby NR circuit incorporates Dolby NR ICs which have no adjustment point.

Perform the following checks and make sure that the IC operates accurately, i.e., accuracy of frequency response through IC.

4.3.1. Dolby NR B-Type Circuit Check

(1) Playback Dolby NR Circuit

Signal Source: 1.4 kHz to negative side of C131 (C231) on Main P.C.B.

Output Connection: VTVM to TP101 (TP201) on Main P.C.B.

Mode: Stop
Monitor SW - Tape
Dolby NR SW - B-Type/OFF

(a) Connect a VTVM to TP101 (TP201) on the Main P.C.B. Ass'y.

(b) Set the Dolby NR switch to B-Type. Feed in 1.4 kHz and adjust the generator output control to obtain 35 mV on the VTVM.

(c) Set the Dolby NR switch to OFF. Check to insure that the reading is +3.2 dB ±1.5 dB on the VTVM.

(2) Record Dolby NR Circuit

Signal Source: 1.4 kHz to Input Jacks

Output Connection: VTVM to TP101 (TP201) and CM6 (CM8) on Main P.C.B.

Mode: Stop
Monitor SW - Source
Dolby NR SW - B-Type/OFF

(a) Connect a VTVM to TP101 (TP201) on the Main P.C.B. Ass'y.

(b) Feed in 1.4 kHz and adjust the Input Level controls to obtain 35 mV/11.1 mV on the VTVM.

(c) Remove the VTVM from TP101 (TP201) and reconnect it to CM6 (CM8) on the Main P.C.B. Ass'y.

(d) Check to insure that the reading at CM6 (CM8) corresponds to the following with Dolby NR switch OFF and B-Type.

Input Level at TP101, TP201	Level at CM6, CM8	
	Dolby NR OFF	Dolby NR B-Type
35 mV	0 dB	+3.2 dB ±1.5 dB
11.1 mV	0 dB	+8.2 dB ±1.5 dB

4.3.2. Dolby NR C-Type Circuit Check

(1) Playback Dolby NR Circuit

Signal Source: 1.4 kHz to negative side of C131 (C231) on Main P.C.B.

Output Connection: VTVM to TP101 (TP201) on Main P.C.B.

Mode: Stop
Monitor SW - Tape
Dolby NR SW - C-Type/OFF

(a) Connect a VTVM to TP101 (TP201) on the Main P.C.B. Ass'y.

(b) Set the Dolby NR switch to C-Type. Feed in 1.4 kHz and adjust the generator output control to obtain 35 mV on the VTVM.

(c) Set the Dolby NR switch to OFF. Check to insure that the reading is +6.5 dB ±1.5 dB on the VTVM.

(2) Record Dolby NR Circuit

Signal Source: 1.4 kHz to Input Jacks

Output Connection: VTVM to TP101 (TP201) and CM6 (CM8) on Main P.C.B.

Mode: Stop
Monitor SW - Source
Dolby NR SW - C-Type/OFF

(a) Connect a VTVM to TP101 (TP201) on the Main P.C.B. Ass'y.

(b) Feed in 1.4 kHz and adjust the Input Level controls to obtain 35 mV/11.1 mV on the VTVM.

(c) Remove the VTVM from TP101 (TP201) and reconnect it to CM6 (CM8) on the Main P.C.B. Ass'y.

(d) Check to insure that the reading at CM6 (CM8) corresponds to the following with Dolby NR switch OFF and C-Type.

Input Level at TP101, TP201	Level at CM6, CM8	
	Dolby NR OFF	Dolby NR C-Type
35 mV	0 dB	+6.5 dB ±1.5 dB
11.1 mV	0 dB	+11.4 dB ±1.5 dB

5. MECHANISM ASS'Y AND PARTS LIST

5.1. Synthesis

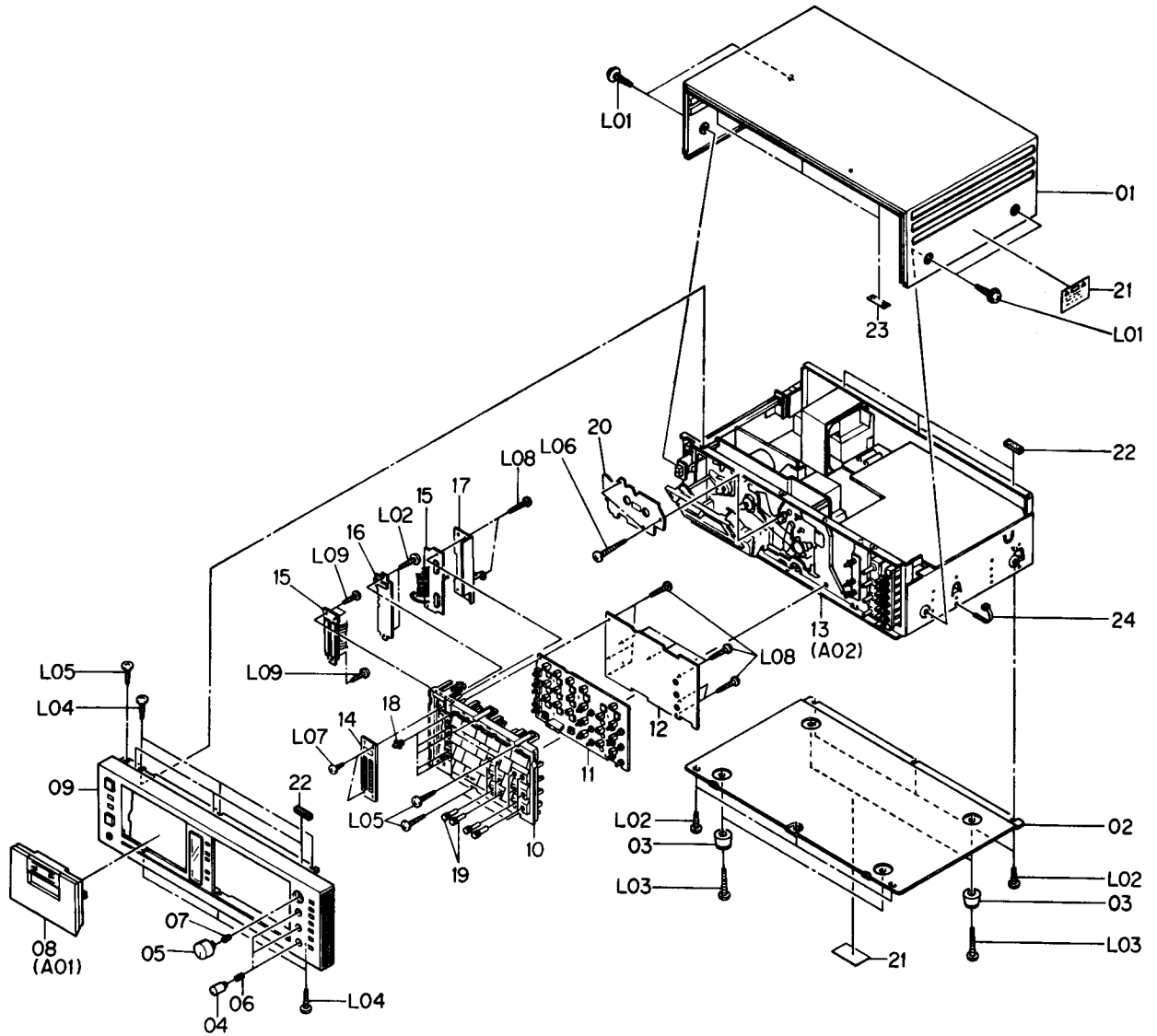

Fig. 5.1

Schematic Ref. No.	Part No.	Description	Q'ty	Schematic Ref. No.	Part No.	Description	Q'ty
	HA04393A	Synthesis (Japan)	1	14	0H04198A	Meter Cover	1
	HA04392A	Synthesis (U.S.A. & Canada)	1	15	BA04893A	Indicator P.C.B. Ass'y	1
	HA04396A	Synthesis (220V Class 2)	1	16	BA04894A	Counter P.C.B. Ass'y	1
	HA04391A	Synthesis (UK)	1	17	0J04698B	Shield Plate	1
	HA04395A	Synthesis (Australia)	1	18	0H04180A	Function Button	5
	HA04394A	Synthesis (Others)	1	19	0H04204A	Calibration Volume Knob	12
		Serial No.: A80101001 -		20	HA04422A	Cover Plate	1
01	0H04010A	Top Cover	1	21	0M04377A	Caution Label (U.S.A. & Canada)	2
02	0J04652A	Bottom Cover	1	22	0J04550A	Top Cover Cushion	6
03	0J03564A	Leg T-H	4	23	0J04080A	Top Cover Himelon	3
04	0H04203A	Volume Knob	3	24	0B08515A	Insu-Lock	1
05	0H04202A	Master Volume Knob	1	L01	0E03032A	BT 4x8 @ Pan (Washer Faced)	4
06	0H03737A	Volume Knob Base	3	L02	0E00857A	BT 3x6 @ Binding	8
07	0H03739A	Master Volume Knob Base	1	L03	0E00865A	BT 3x10 @ Binding	4
08	HA04401A	Cassette Lid Ass'y	1	L04	0E00921A	BT 3x8 @ Binding	6
09	HA04398A	Front Panel Ass'y	1			(Black Chromate)	
10	HA04399A	Front Panel Escutcheon Ass'y	1	L05	0E00868A	BT 3x8 @ Binding	3
11	BA04892A	Control P.C.B. Ass'y	1	L06	0E00950A	BT 3x14 @ Pan (Black Chromate)	2
12	0J04707A	Insulator	1	L07	0E00869A	BT 2.6x4 @ Binding	2
13	JA03971A	Chassis Ass'y (Japan)	1	L08	0E00954A	BT 2.6x8 @ Binding	10
	JA03970A	Chassis Ass'y (U.S.A. & Canada)	1	L09	0E00859A	BT 2.6x6 @ Binding	3
	JA03974A	Chassis Ass'y (220V Class 2)	1				
	JA03969A	Chassis Ass'y (UK)	1				
	JA03973A	Chassis Ass'y (Australia)	1				
	JA03972A	Chassis Ass'y (Others)	1				

5.2. Cassette Lid Ass'y (A01)

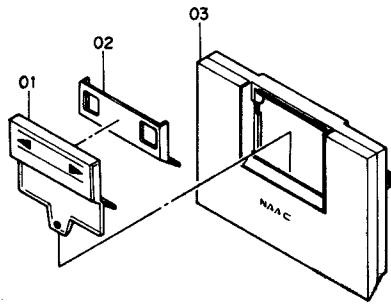

Fig. 5.2

5.3. Chassis Ass'y (A02)

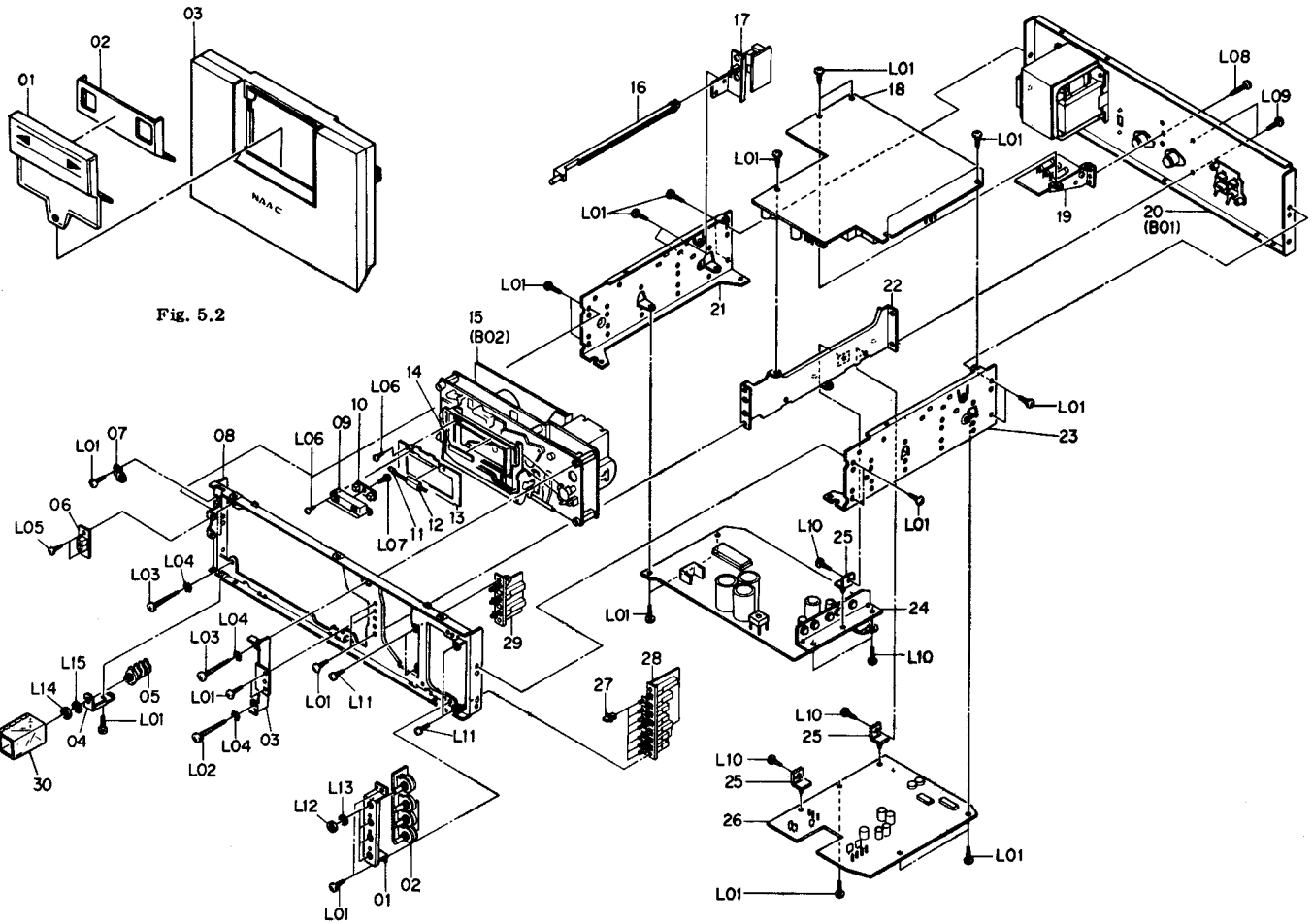

Fig. 5.3

Schematic Ref. No.	Part No.	Description	Q'ty	Schematic Ref. No.	Part No.	Description	Q'ty
A01	HA04401A	Cassette Lid Ass'y Serial No.: A80101001 -	1	18	BA04870A	Main P.C.B. Ass'y	1
01	OH04189A	Lid Cover	1	19	BA04899A	Fuse P.C.B. Ass'y (U.S.A., Canada & Others)	1
02	OH04187A	Indicator Reflector	1		BA04900A	Fuse P.C.B. Ass'y (UK, 220V Class 2 & Australia)	1
03	HA04414A	Cassette Lid Sub Ass'y	1		BA04898A	Fuse P.C.B. Ass'y (Japan)	1
A02	JA03969A	Chassis Ass'y (UK)	1		HA04403A	Rear Panel Ass'y (UK)	1
	JA03970A	Chassis Ass'y (U.S.A. & Canada)	1		HA04408A	Rear Panel Ass'y (U.S.A. & Canada)	1
	JA03971A	Chassis Ass'y (Japan)	1		HA04404A	Rear Panel Ass'y (Japan)	1
	JA03972A	Chassis Ass'y (Others)	1		HA04405A	Rear Panel Ass'y (Others)	1
	JA03973A	Chassis Ass'y (Australia)	1		HA04406A	Rear Panel Ass'y (Australia)	1
	JA03974A	Chassis Ass'y (220V Class 2) Serial No.: A80101001 -	1		HA04407A	Rear Panel Ass'y (220V Class 2)	1
01	OJ04643A	Volume Holder	1	21	OJ04650A	Side Chassis L	1
02	BA04890A	Volume P.C.B. Ass'y	1	22	OJ04649A	Center Chassis	1
03	OJ04135A	Mechanism Bracket	1	23	OJ04651A	Side Chassis R	1
04	OJ04644A	Headphone Jack Holder	1	24	BA04886A	Logic P.C.B. Ass'y	1
05	OB08511A	Headphone Jack	1	25	OB08771A	Hinge	1
06	BA04897A	Timer Switch P.C.B. Ass'y	1	26	BA04879A	Auto Azimuth P.C.B. Ass'y	1
07	OJ04645A	Power Switch Bar Holder	1	27	OH04179A	Function Button A	7
08	OJ04648A	Front Chassis	1	28	BA04889A	Switch P.C.B. Ass'y	1
09	OH04186A	Indicator Cover	1	29	BA04891A	Tape Select P.C.B. Ass'y	1
10	BA04895A	Direction P.C.B. Ass'y	1	30	OJ04516A	Headphone Jack Cover	1
11	OB02228B	Lamp 14V 50mA	1	L01	OE00857A	BT 3x6 ⊕ Binding (Chromate)	31
12	OJ04506C	Lamp Holder	1	L02	OE00924A	BT 4x16 ⊕ Binding (Chromate)	1
13	OJ04637A	Cassette Case Plate	1	L03	OE00944A	BT 4x15 ⊕ Binding (Black Chromate)	3
14	BA04896A	Connector P.C.B. Ass'y	1	L04	OE00078A	Washer 4mm Toothed Lock	4
15	CA08445A	Mechanism Ass'y	1	L05	OE03022A	BT 2x4 ⊕ Binding (Black Chromate)	2
16	OJ04604B	Power Switch Bar	1	L06	OE00869A	BT 2x4 ⊕ Binding (Chromate)	1
17	BA04947A	Power Switch P.C.B. Ass'y (U.S.A. & Canada)	1	L07	OE00873A	BT 2.6x5 ⊕ Binding (Chromate)	1
	BA04948A	Power Switch P.C.B. Ass'y (UK, 220V Class 2, Australia & Others)	1	L08	OE00921A	BT 3x8 ⊕ Binding (Black Chromate)	1
	BA04946A	Power Switch P.C.B. Ass'y (Japan)	1	L09	OE00860A	BT 3x6 ⊕ Binding (Black Chromate)	2
				L10	OE00612A	M3x6 ⊕ Pan	3

5.4. Rear Panel Ass'y (B01)

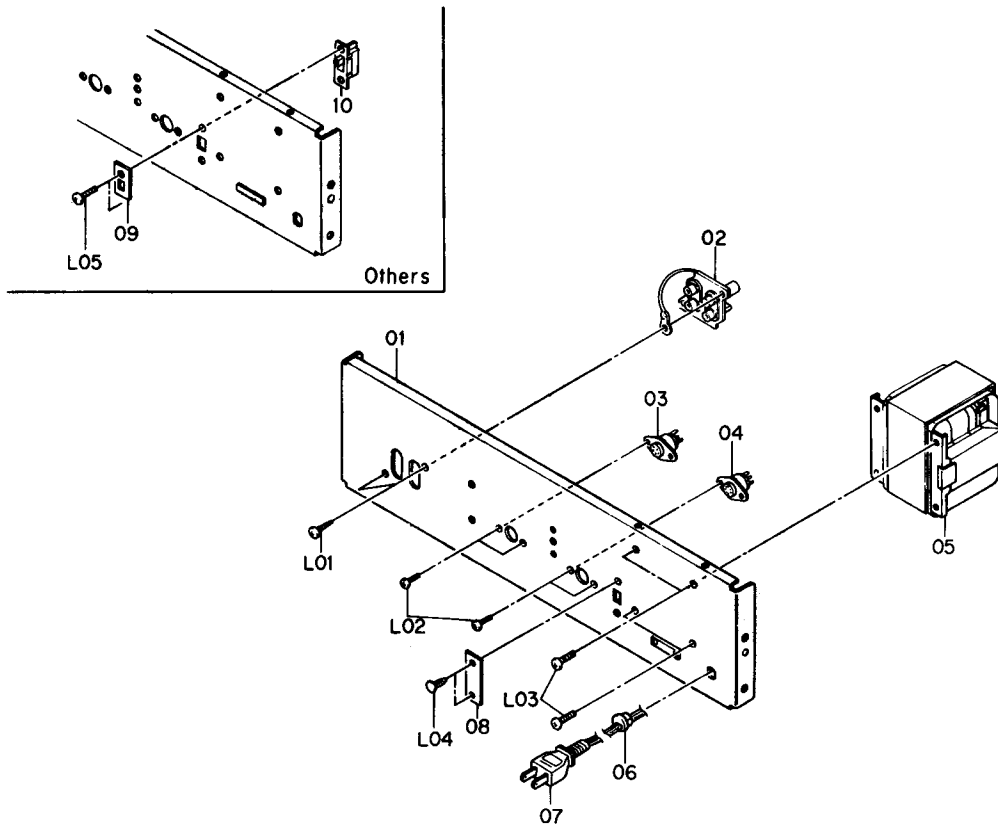

Fig. 5.4

Schematic Ref. No.	Part No.	Description	Q'ty	Schematic Ref. No.	Part No.	Description	Q'ty
B01	HA04408A	Rear Panel Ass'y (U.S.A. & Canada)	1	L03	0E00953A	M4x10 \oplus Binding (Black Chromate)	4
	HA04404A	Rear Panel Ass'y (Japan)	1	L04	0B08583A	Plastic Rivet (U.S.A., Canada, Japan, 220V Class 2, UK & Australia)	2
	HA04405A	Rear Panel Ass'y (Others)	1	L05	0E00594A	M3x8 \oplus Binding (Bronze) (Others)	2
	HA04403A	Rear Panel Ass'y (UK)	1				
	HA04407A	Rear Panel Ass'y (220V Class 2)	1				
	HA04406A	Rear Panel Ass'y (Australia)	1				
	Serial No.: A80101001 -						
01	OH04205A	Rear Panel	1				
02	BA04945A	Pin Jack P.C.B. Ass'y	1				
03	BA04944A	4P DIN Socket Ass'y	1				
04	BA04949A	8P DIN Socket Ass'y	1				
05	OB06639B	Power Transformer (U.S.A. & Canada)	1				
	OB06640B	Power Transformer (Japan)	1				
	OB06637B	Power Transformer (Others)	1				
	OB06638B	Power Transformer (UK, Australia & 220V Class 2)	1				
06	OB08037U	Cord Bushing C (U.S.A., Canada, Japan, 220V Class 2, Australia & Others)	1				
	OB08351A	Cord Bushing 4K-4 (UK)	1				
07	OB08533A	Power Cord (U.S.A. & Canada)	1				
	OB08219B	Power Cord (Japan)	1				
	OB08348A	Power Cord (UK)	1				
	OB08093U	Power Cord (220V Class 2)	1				
	OB05241A	Power Cord (Australia)	1				
08	OJ04601B	Switch Cover (U.S.A., Canada, Japan, 220V Class 2, UK & Australia)	1				
09	OM03946A	Voltage Selector Lock Plate C (Others)	1				
10	OB07092U	Voltage Selector (Others)	1				
L01	0E00921A	BT 3x8 \oplus Binding (Black Chromate)	2				
L02	0E00714A	M2.6x6 \oplus Binding (Bronze)	4				

5.5. Mechanism Ass'y (B02)

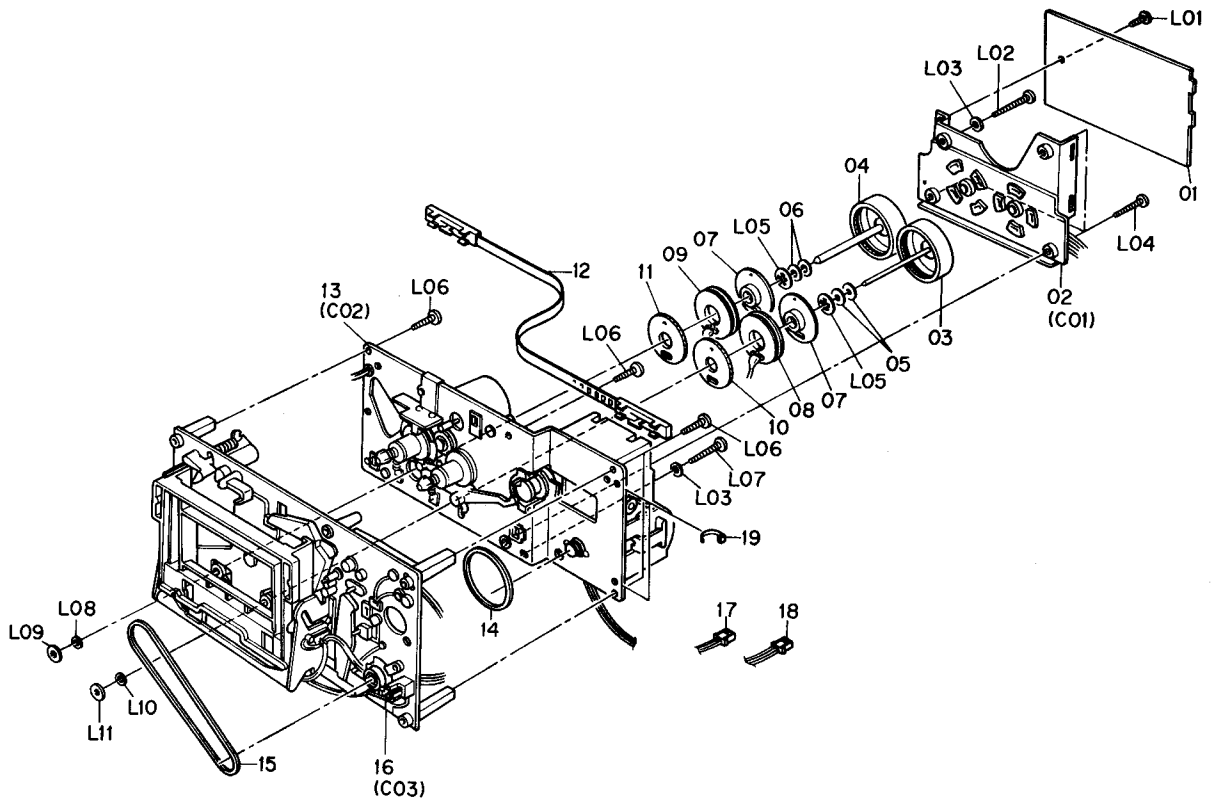

Fig. 5.5

5.6. Flywheel Holder Ass'y (C01)

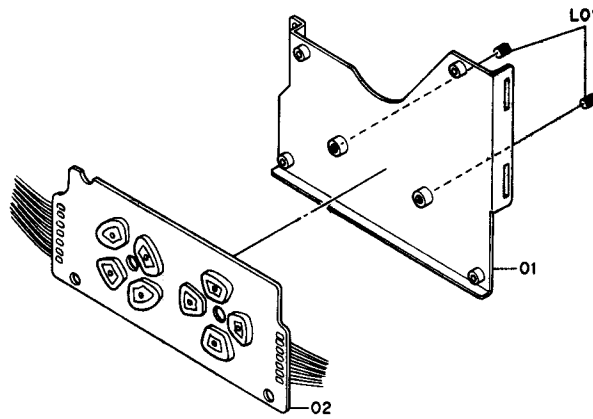

Fig. 5.6

5.7. Sub Mechanism Chassis Ass'y (C02)

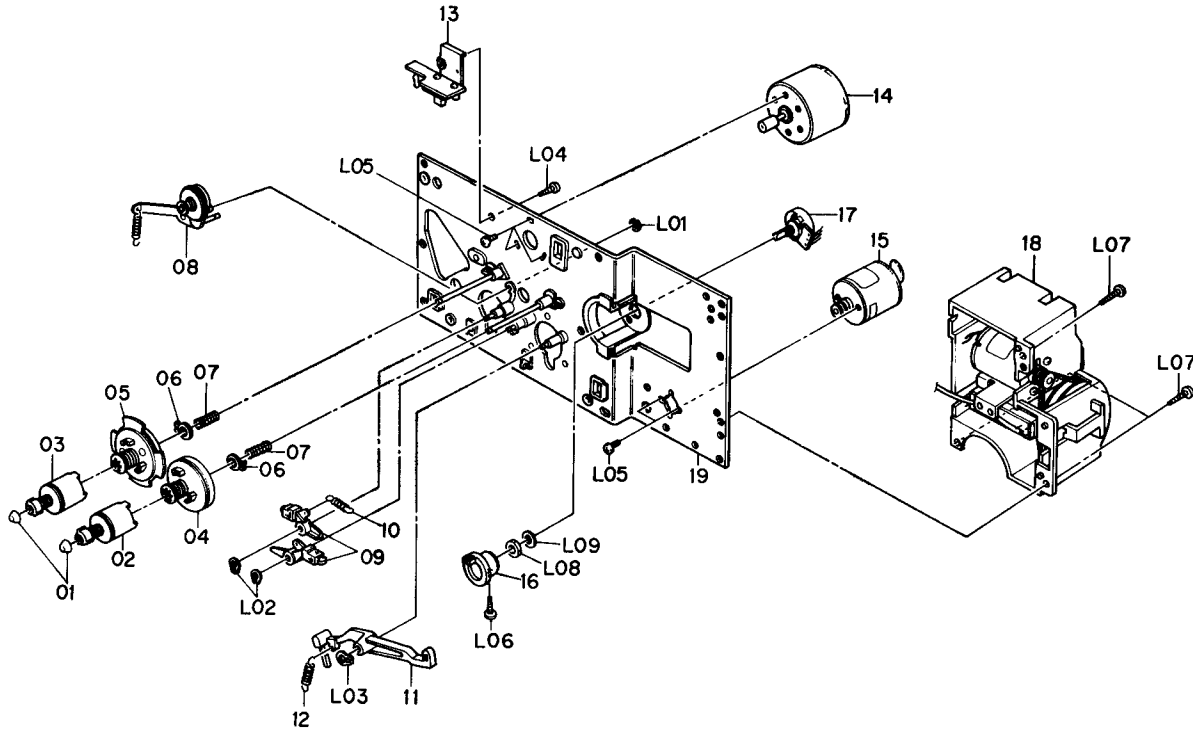

Fig. 5.7

Schematic Ref. No.	Part No.	Description	Q'ty	Schematic Ref. No.	Part No.	Description	Q'ty
B02	CA08445A	Mechanism Ass'y Serial No.: A80101001 -	1	C02	CA08444A	Sub Mechanism Chassis Ass'y Serial No.: A80101001 -	1
01	BA04941A	Motor Control P.C.B. Ass'y	1	01	OC08039B	Reel Hub Head	2
02	CA08422A	Flywheel Holder Ass'y	1	02	CA08038B	Reel Hub B Pulley Ass'y	1
03	CA08433A	Take-up Flywheel Sub Ass'y	1	03	CA08397A	Reel Hub S Pulley Ass'y	1
04	CA08434A	Supply Flywheel Sub Ass'y	1	04	CA08037A	Reel Hub Take-up Ass'y	1
05	OC08020B	Thrust Washer 2.6mm	2	05	CA08452A	Reel Hub Supply Ass'y	1
06	OC08021B	Thrust Washer 3.1mm	2	06	CA08039A	Back Tension Ass'y	2
07	OC08333A	Sensor Plate	2	07	OC08269A	Back Tension Spring C	2
08	CA08391A	Sensor Coil Take-up Sub Ass'y	1	08	CA08193A	Idler Ass'y	1
09	CA08454A	Sensor Coil Supply Sub Ass'y	1	09	CA08042A	Brake Ass'y	2
10	CA08483A	Sensor Gear Take-up Ass'y	1	10	OC08129B	Brake Arm Spring	1
11	CA08485A	Sensor Gear Supply Ass'y	1	11	OC08030C	Brake Drive Arm	1
12	OC08237A	Azimuth Wire	1	12	OC08128A	Brake Drive Arm Spring	1
13	CA08444A	Sub Mechanism Chassis Ass'y	1	13	BA04943A	Counter Pulse Generator P.C.B. Ass'y	1
14	OC08099B	Cam Motor Belt	1	14	CA08242A	Reel Motor Ass'y	1
15	OC08098B	Counter Belt B	1	15	CA08034A	Control Motor Ass'y	1
16	CA08443A	Main Mechanism Chassis Ass'y	1	16	OC08053B	Volume Coupler	1
17	OB02333B	3P-H Connector (Blue with Shield)	1	17	OB07240A	Volume Control 10K (B)	1
18	OB08672A	3P-H Connector	1	18	CA08453A	Playback Head Azimuth Alignment Motor Ass'y	1
19	OB08515A	Insu-Lock	1	19	CA08194A	Sub Chassis Ass'y B	1
L01	OE00857A	BT 3x6 Pan	1	L01	OE00698A	E-Ring 2.5mm	1
L02	OE00834A	BT 3x30 Pan	1	L02	OE00837A	Stopper Ring 3mm	2
L03	OE00178A	Washer 3.3x8x0.5	2	L03	OE00838A	Stopper Ring 4mm	1
L04	OE00833A	BT 3x20 Pan	3	L04	OE00859A	BT 2.6x6 Binding	1
L05	OE03023A	Stopper Ring 8mm	2	L05	OE00226A	M2.6x4 Pan	5
L06	OE00883A	BT 3x18 Pan	5	L06	OE00792A	BT 2.6x6 Pan	1
L07	OE00835A	BT 3x25 Pan	1	L07	OE00846A	BT 3x8 Pan	3
L08	OC08347A	Washer 3.1mm FT	1	L08	-	Volume Nut	(1)
L09	OC08345A	Capstan Washer 3mm	1	L09	-	Volume Washer	(1)
L10	OC08348A	Washer 2.6mm FT	1				
L11	OC08346A	Capstan Washer 2.5mm	1				
C01	CA08422A	Flywheel Holder Ass'y Serial No.: A80101001 -	1				
01	CA08382B	Flywheel Holder Sub Ass'y	1				
02	BA04942A	Motor P.C.B. Ass'y	1				
L01	OC08068C	Thrust Screw	2				

5.8. Main Mechanism Chassis Ass'y (C03)

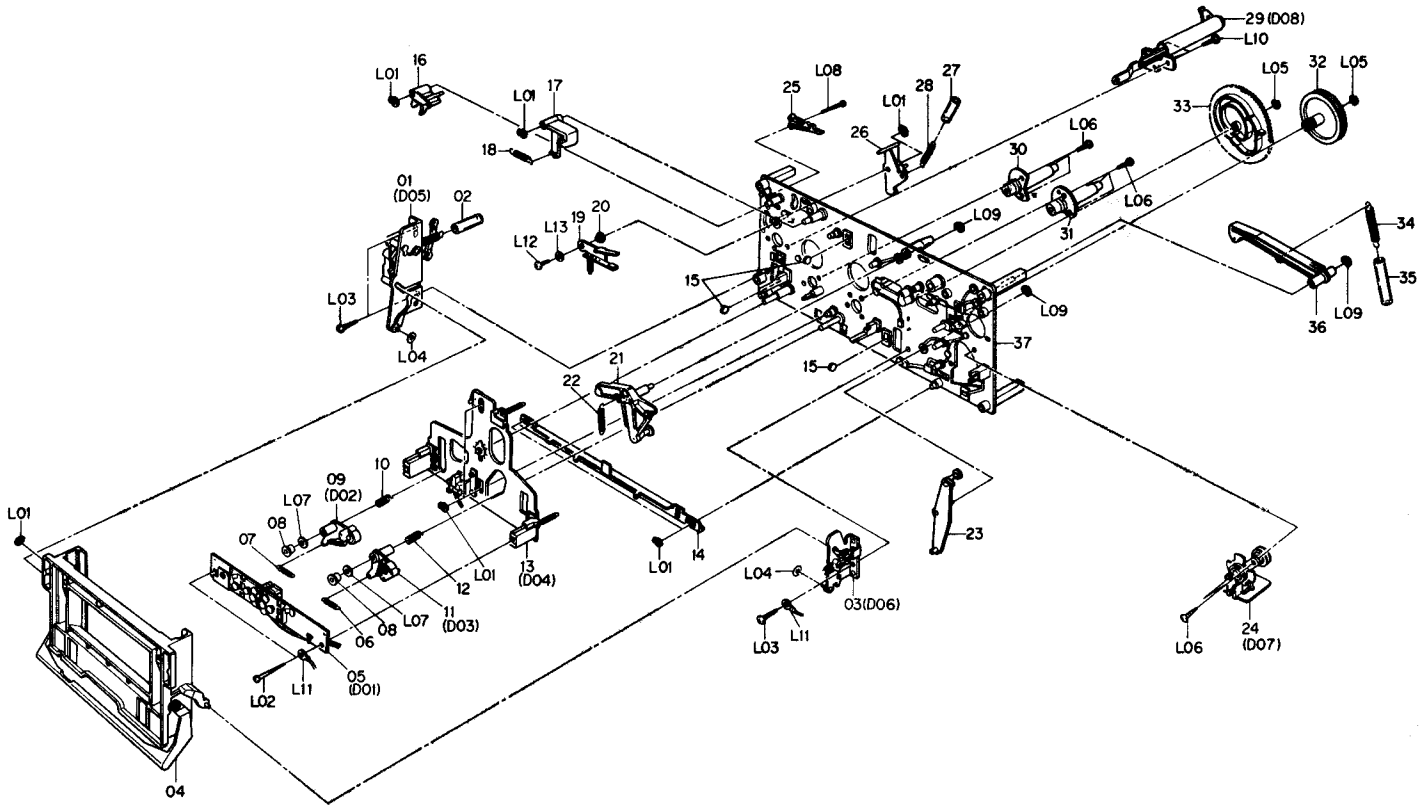

Fig. 5.8

Schematic Ref. No.	Part No.	Description	Q'ty	Schematic Ref. No.	Part No.	Description	Q'ty
C03	CA08443A	Main Mechanism Chassis Ass'y Serial No.: A80101001 -	1	36	CA08028A	Counter-Load Arm	1
				37	CA08347A	Main Chassis Ass'y	1
01	CA08350A	Cassette Case Holder L Ass'y	1	L01	0E00837A	Stopper Ring 3mm	9
02	0C08152A	Lid Arm Spring Tube	1	L02	0E00834A	BT 3x30 @ Pan	2
03	CA08455A	Cassette Case Holder R Ass'y	1	L03	0E00831A	BT 3x10 @ Pan	3
04	CA08451A	Cassette Case Ass'y	1	L04	0E00254A	Washer 3.1mm	2
05	CA08438A	Head Mount Base Ass'y	1	L05	0E00222A	E-Ring 2mm	2
06	0C08250A	Take-up Roller Arm Spring	1	L06	0E00876A	BT 2.6x8 @ Pan	8
07	0C08121A	Supply Roller Arm Spring	1	L07	0E00178A	Washer 3mm	2
08	0C08313A	Pressure Roller Arm Bushing	2	L08	0E00879A	BT 2x15 @ Pan	1
09	CA08437A	Supply Pressure Roller Arm Ass'y	1	L09	0E00838A	Stopper Ring 4mm	3
10	0C08122C	Supply Pressure Roller Thrust Spring	1	L10	0E00846A	BT 3x8 @ Pan	3
				L11	0E00895A	Earth Lug 3mm	2
11	CA08436A	Take-up Pressure Roller Arm Ass'y	1	L12	0E00859A	BT 2.6x6 @ Binding	1
12	0C08183B	Take-up Pressure Roller Thrust Spring	1	L13	0C08255A	Washer 2.6mm	1
13	CA08339A	Head Base Ass'y	1				
14	0C08368A	Pressure Roller Drive Bar D	1				
15	0C08086B	Head Base Roller	3				
16	0C08050B	Record Sensor Arm	1				
17	0C08051E	Cassette Hold Arm	1				
18	0C08120A	Cassette Hold Arm Spring	1				
19	0C08371A	Back Tension Arm Ass'y	1				
20	0C08254A	Back Tension Arm Collar	1				
21	0C08027A	Head Base Drive Arm Ass'y	1				
22	0C08143C	Head Base Drive Arm Spring	1				
23	CA08026A	Pressure Roller Drive Arm Ass'y	1				
24	CA08441A	Auto Shut-off Ass'y	1				
25	0C08119A	Record Protector	1				
26	0C08194C	Damper Lock Arm	1				
27	0C08153A	Damper Lock Arm Spring Tube	1				
28	0C08116A	Record Arm Spring	1				
29	CA08030A	Pneumatic Damper Ass'y	1				
30	CA08404B	Supply DD Flange Ass'y	1				
31	CA08457A	Take-up DD Flange Ass'y	1				
32	CA08186A	Cam Drive Gear	1				
33	0C08029H	Control Cam	1				
34	0C08117A	Counter-Load Arm Spring	1				
35	0C08152A	Counter-Load Arm Spring Tube	1				

5.9. Head Mount Base Ass'y (D01)

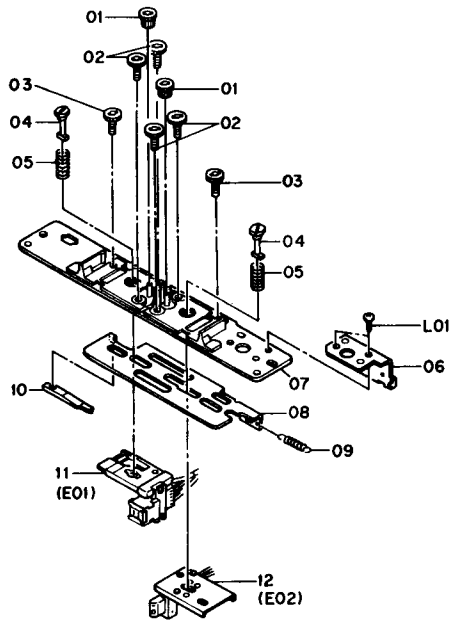

Fig. 5.9

5.10. Supply Pressure Roller Ass'y (D02)

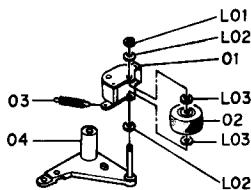

Fig. 5.10

5.11. Take-up Pressure Roller Ass'y (D03)

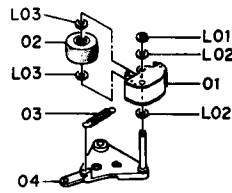

Fig. 5.11

5.12. Head Base Ass'y (D04)

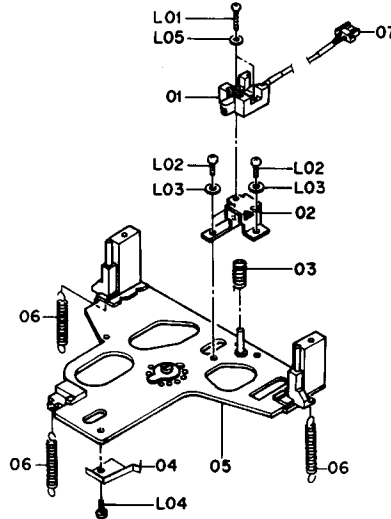

Fig. 5.12

5.13. Cassette Case Holder L Ass'y (D05)

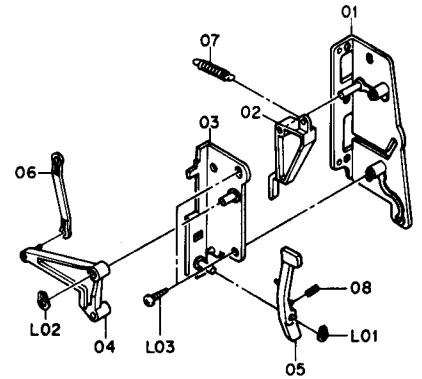

Fig. 5.13

Schematic Ref. No.	Part No.	Description	Q'ty	Schematic Ref. No.	Part No.	Description	Q'ty
D01	CA08438A	Head Mount Base Ass'y Serial No.: A80101001 -	1	L01	0E00042A	E-Ring 1.5mm	1
01	OC08028C	Head Height Adjustment Screw	2	L02	0C08024A	Washer 2mm 0.25T	2
02	OC08027F	Head Height Adjustment Gear	4	L03	0C08365A	Washer 2mm 0.13T	2
03	OC08026D	Azimuth Alignment Screw	2	D04	CA08339A	Head Base Ass'y Serial No.: A80101001 -	1
04	OC08161B	Spring Stopper	2	01	GA02103A	EOK Erase Head	1
05	OC08187B	Head Plate Spring	2	02	OC08158D	Erase Head Hold Plate	1
06	OC08315A	Azimuth Alignment Wire Hold Plate	1	03	OC08166A	Erase Head Hold Plate Spring	1
07	CA08083D	Head Mount Base Sub Ass'y	1	04	OC08174D	Cassette Hold Spring	1
08	OC08352A	AP Drive Plate	1	05	CA08003R	Head Base Ass'y	1
09	OC08362A	TG Spring	1	06	OC08175A	Head Base L Spring	3
10	OC08351A	PH Azimuth Plate	1	07	0B08944A	2P-H Connector	1
11	CA08439A	PA-1L Playback Head Ass'y	1	L01	0E00951A	M1.7x7 @Pan (Black Chromate)	2
12	CA08440A	R-8L Record Head Ass'y	1	L02	0E00909A	M2x6 @Pan	3
L01	0E00917A	BT 2.6x5 @Pan	2	L03	0E00117A	Washer 2mm	3
				L04	0E00853A	BT 2x3 @Pan	1
				L05	0E00952A	Washer 1.7mm	2
D02	CA08437A	Supply Pressure Roller Arm Ass'y Serial No.: A80101001 -	1	D05	CA08350A	Cassette Case Holder L Ass'y Serial No.: A80101001 -	1
01	CA08403A	Supply Tape Guide	1	01	CA08326B	Cassette Case Holder L Sub Ass'y	1
02	OC08357A	Pressure Roller	1	02	OC08073C	Lid Arm A	1
03	OC08495A	Supply Guide Spring	1	03	OC08306A	Eject Arm Holder	1
04	CA08401A	Supply Roller Arm Ass'y	1	04	OC08307A	Eject Arm A	1
L01	0E00042A	E-Ring 1.5mm	1	05	OC08197C	Eject Arm B	1
L02	0C08024A	Washer 2mm 0.25T	2	06	OC08199B	Eject Arm Joint	1
L03	0C08365A	Washer 2mm 0.13T	2	07	OC08114A	Lid Arm Spring	1
				08	OC08211C	Eject Arm Spring	1
D03	CA08436A	Take-up Pressure Roller Arm Ass'y Serial No.: A80101001 -	1	L01	0E00837A	Stopper Ring 3mm	1
01	CA08402A	Take-up Tape Guide	1	L02	0E00838A	Stopper Ring 4mm	1
02	OC08357A	Pressure Roller	1	L03	0E00865A	BT 3x10 @ Binding	2
03	OC08362A	Take-up Guide Spring	1				
04	CA08400A	Take-up Roller Arm Sub Ass'y	1				

5.14. Cassette Case Holder R Ass'y (D06)

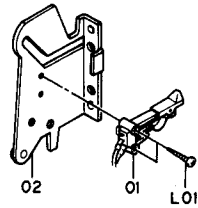

Fig. 5.14

5.15. Auto Shut-off Ass'y (D07)

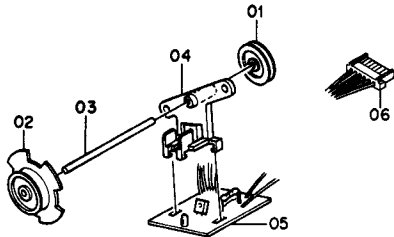

Fig. 5.15

5.16. Pneumatic Damper Ass'y (D08)

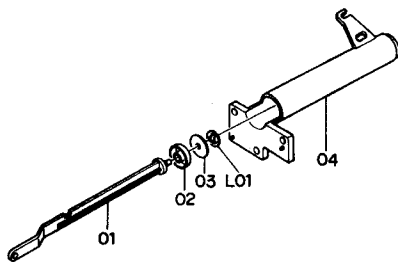

Fig. 5.16

5.17. PA-1L Playback Head Ass'y (E01)

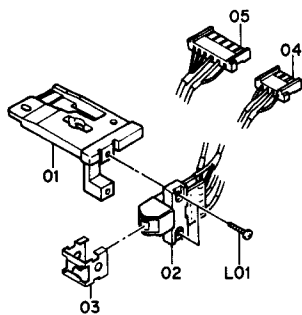

Fig. 5.17

5.18. R-8L Record Head Ass'y (E02)

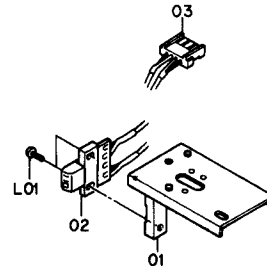

Fig. 5.18

Schematic Ref. No.	Part No.	Description	Q'ty
D06	CA08455A	Cassette Case Holder R Ass'y Serial No.: A80101001 -	1
01	OC08133A	Eject Sensor	1
02	CA08427A	Cassette Case Holder R Sub Ass'y	1
L01	0E00840A	BT 2x8 @ Pan	1
D07	CA08441A	Auto Shut-off Ass'y Serial No.: A80101001 -	1
01	OC08047A	Shut-off Pulley A	1
02	OC08309B	Shut-off Pulley B	1
03	OC08088B	Shut-off Pulley Shaft	1
04	OC08207B	Shut-off Pulley Holder	1
05	BA04852A	Shut-off P.C.B. Ass'y	1
06	0B02339B	6P-H Connector	1
D08	CA08030A	Pneumatic Damper Ass'y Serial No.: A80101001 -	1
01	OC08058C	Damper Piston	1
02	OC08102C	Damper Ring	1
03	OC08010C	Damper Plate	1
04	OC08059D	Cylinder	1
L01	0E00874A	Stopper Ring CS 2mm	1
E01	CA08439A	PA-1L Playback Head Ass'y Serial No.: A80101001 -	1
01	OC08350B	Playback Head Plate	1
02	GA02162A	PA-1L Playback Head	1
03	OC08349C	Tape Protector	1
04	0B02341B	4P-H Connector	1
05	0B02342B	6P-H Connector	1
L01	0E00886A	M1.7x6.5 @ Pan	1
E02	CA08440A	R-8L Record Head Ass'y Serial No.: A80101001 -	1
01	CA08308A	Record Head	1
02	GA01050A	R-8L Record Head	1
03	0B02340B	4P-H Connector	1
L01	0E00887A	M1.7x4 @ Pan	2

6. MOUNTING DIAGRAMS AND PARTS LIST

Notes: 1. Mounting diagram shows a dip side view of the printed circuit board.

2. Diode is 1SS53, 1S1555, or 1SS176 unless otherwise specified.

3. Following transistors are interchangeable with each other.

a. 2SA733, 2SA608SP, 2SA1048, 2SA1175

b. 2SC945, 2SC536SP, 2SC2458, 2SC2785

4. Abbreviation for part name:

TR — Transistor, SiD — Silicon Diode, GD — Germanium Diode, ZD — Zener Diode

RK — Carbon Resistor, RM — Metal Film Resistor, RF — Fail Safe Type Resistor, RC — Cement Resistor,

RW — Wire Wound Resistor

CE — Electrolytic Capacitor, CM — Mylar Capacitor, CC — Ceramic Capacitor, CP — PP Capacitor,

CT — Tantalum Capacitor, CF — Film Capacitor, C — Mica Capacitor

6.1. Power Switch P.C.B. Ass'y

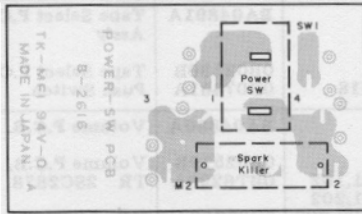

Fig. 6.1

6.2. Fuse P.C.B. Ass'y

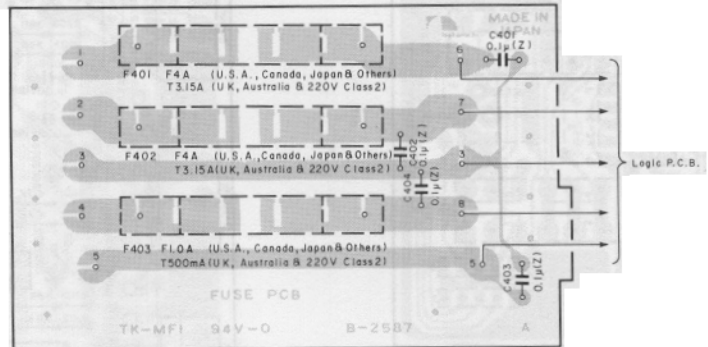

Fig. 6.2

6.3. Shut-off P.C.B. Ass'y

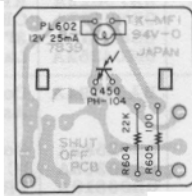

Fig. 6.3

6.4. Counter Pulse Generator P.C.B. Ass'y

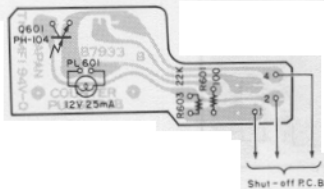

Fig. 6.4

Schematic Ref. No.	Part No.	Description	Schematic Ref. No.	Part No.	Description	Schematic Ref. No.	Part No.	Description
	BA04947A	Power Switch P.C.B. Ass'y (U.S.A. & Canada)		BA04899A	Fuse P.C.B. Ass'y (U.S.A., Canada & Others)		OM04432A	Fuse Label 4A 125V x 2 (U.S.A., Canada & Others) (1)
	BA04946A	Power Switch P.C.B. Ass'y (Japan)		BA04898A	Fuse P.C.B. Ass'y (Japan)		OM04441A	Fuse Label 4A 250V x 2 (Japan) (1)
	BA04948A	Power Switch P.C.B. Ass'y (UK, Australia, 220V Class 2 & Others)		BA04900A	Fuse P.C.B. Ass'y (UK, Australia & 220V Class 2)		OM03936B	Fuse Label T3.15A 250V (UK, Australia & 220V Class 2) (1)
SW1	OB02616A	Power Switch P.C.B.	C401,402	OB02587A	Fuse P.C.B.		OB08349A	Fuse Clip (UK, Australia & 220V Class 2) (6)
SW1	OB07407A	Power Switch (U.S.A. & Canada)	403,404	OBT9292A	CC 0.1µ 50V Z			
SW1	OB07406A	Power Switch (Japan)	F401,402	OB90002A	Fuse F4A 125V (U.S.A., Canada & Others)		BA04852A	Shut-off P.C.B. Ass'y
SW1	OB07408A	Power Switch (UK, Australia, 220V Class 2 & Others)	F401,402	OB90001A	Fuse F4A 250V (Japan)	Q450 R604 R605 PL602	OB07839B	Shut-off P.C.B.
M2	OB08342A	Spark Killer (U.S.A. & Canada)	F401,402	OB08281A	Fuse T3.15A 250V (UK, Australia & 220V Class 2)		OB06228A	Photo TR PH104
M2	OB08363A	Spark Killer (Japan)	F403	OB08374A	Fuse F1A 250V (U.S.A., Canada & Others)		OB05615A	RF 100 1/4W J
M2	OB08955A	Spark Killer (UK, Australia, 220V Class 2 & Others)	F403	OB08686A	Fuse F1A 250V (Japan)		OB09215A	RF 100 1/4W J
	OE00622A	M3x5 ⊕ Pan (2A) (2)	F403	OB08457A	Fuse T500mA 250V (UK, Australia & 220V Class 2)		OB08552A	Lamp 12V 25mA
	OE00752A	Eyelet 2x3 (2)		OM04190A	Fuse Label 1A 250V (U.S.A., Canada & Japan) (1)	Q601 R601 R603 PL601	BA04943A	Counter Pulse Generator P.C.B. Ass'y
	OJ04646A	Power Switch Holder (1)		OM04096C	Fuse Label T500mA (UK, Australia & 220V Class 2) (1)		OB07933B	Counter Pulse Generator P.C.B.
							OB06228A	Photo TR PH104
							OB09215A	RF 100 1/4W J
							OB05661A	RF 22K 1/4W J
							OB08552A	Lamp 12V 25mA
							OC08281B	P.C.B. Holder (1)
							OE00792A	BT 2.6x6 ⊕ Pan (Chromate) (2)

6.12. Control P.C.B. Ass'y

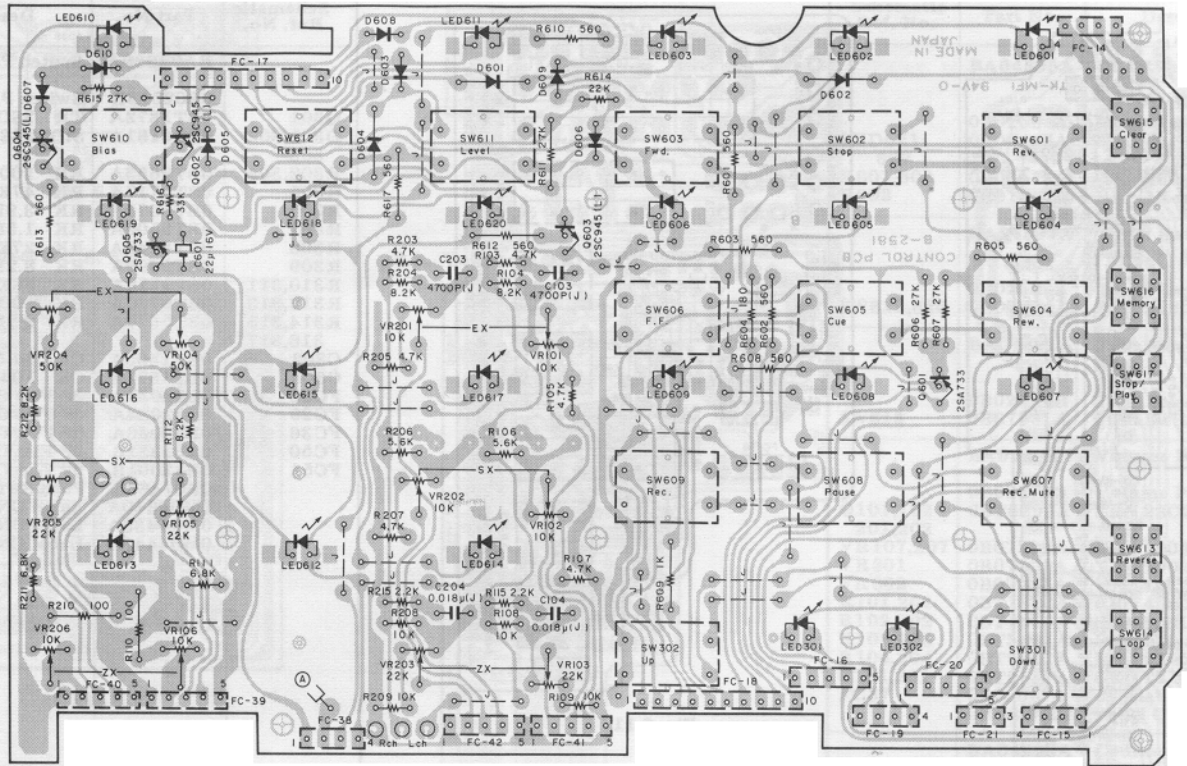

Fig. 6.12

6.13. Motor Control P.C.B. Ass'y

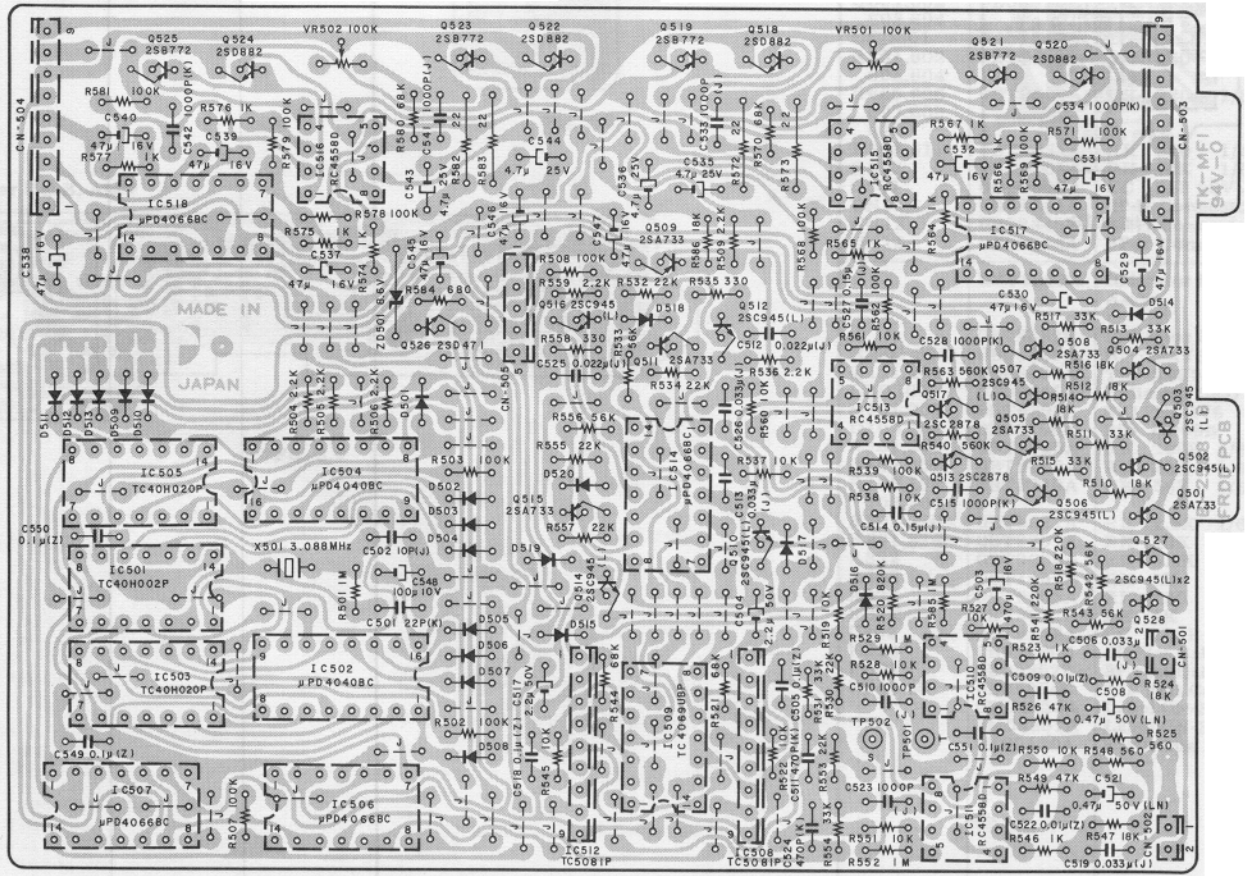

Fig. 6.13

Schematic Ref. No.	Part No.	Description	Schematic Ref. No.	Part No.	Description	Schematic Ref. No.	Part No.	Description
	BA04886A	Logic P.C.B. Ass'y	D602-611	OBT6398A	SID 1SS176 (27)	R706	OBT9711A	RK 27K 1/6W J
	-- DC Supply --		614-619			R712,713	OBT5509A	RK 33K 1/4W J
IC401	OB06124B	IC JRC4558D	623,624			R717	OBT1683A	RK 15K 1/4W J
Q403,404	OBT1872A	TR 2SC945L (P,Q)	626-633			R731	OB09217A	RF 5.6 1/4W J
409,414			640	OB08908A	Xtal KBR400BT	C601,602	OBT9283A	CC 220P 50V K
415			X601	OB02307A	Xtal KBR800H	C603,604	OBT1405A	CE 1μ 50V
Q407,408	OBT6013A	TR 2SA733 (P,Q)	X602	OB07258A	Semi-fixed VR 220K	630		
411			VR601	OB07257A	Semi-fixed VR 100K	C606,615	OBT1402A	CE 4.7μ 25V
Q410,412	OBT6322A	TR 2SC2002 (K,L)	VR602	OB07329A	Semi-fixed VR 2K	618		
Q416	OBT1426A	TR 2SA562 (O,Y)	VR603	OB07256A	Semi-fixed VR 10K	C607	OBT9852A	CF 4700P 50V J
ZD401	OBT6058A	ZD 5.1V YZ051	VR604	OBT9725A	RK 100K 1/6W J	C608,609	OBT9282A	CC 100P 50V K
ZD402	OBT6384A	ZD 5.5V XZ055	R601,607			C612,613	OBT1412A	CE 10μ 16V
D401	OB06283A	Diode Bridge DBA30	608,611			C614	OBT9276A	CC 5P 50V J
D402,403	OB06109A	SID GP08B	612,613			C616	OBT1502A	CE 330μ 16V
D404	OB06282A	Diode Bridge DBA10	614,615			C617	OBT9327A	CE 0.33μ 50V (LN)
D405,406	OBT6398A	SID 1SS176	627,632			C619	OBT9865A	CF 0.056μ 50V J
D407	OBT6181A	SID 1SS53	649,667			C620	OBT9370A	CC 33P 50V J
R401,426	OBT1857A	RK 1K 1/4W J	672,693			CN7	OB02347A	3P-T Post BLU
R402	OBT1679A	RK 100 1/4W J	694,696			CN8	OB08653A	3P-T Post
R403	OBT1846A	RK 4.7K 1/4W J	703,704			CN9	OB02286A	6P-T Post BLU
R404	OBT1888A	RK 10K 1/4W J	709,710			CN10	OB08642A	6P-T Post
R405,415	OBT5671A	RK 2.2M 1/4W J	720,721			CN11	OB08656A	2P-T Post
R406	OBT9528A	RM 13.7K 1/4W F	722,726			CN12	OB08654A	4P-T Post
R407	OBT9203A	RM 10K 1/4W F	727,734			CN13	OB08644A	8P-T Post
R408	OBT1887A	RK 5.6K 1/4W J	R603,651	OBT5622A	RK 2.2K 1/4W J		OB08964A	TR Mica TO-126 (2)
R409	OBT5794A	RK 680 1/4W J	R604,609	OBT9749A	RK 1M 1/6W J		OE00507A	Nut Hex. M3 (2)
R410,417	OBT9504A	RM 11K 1/4W F	610,708				OE00510A	M3x8 ⊕ Pan (2A)
R411	OBT9677A	RK 1K 1/6W J	736					(2)
R412	OBT9653A	RK 100 1/6W J	R605,616	OBT9701A	RK 10K 1/6W J			(1)
R413,431	OBT9693A	RK 4.7K 1/6W J	617,629					
R414	OBT9701A	RK 10K 1/6W J	639,659					
R416,420	OBT9695A	RK 5.6K 1/6W J	661,662					
421			676,681					
R418,425	OBT9725A	RK 100K 1/6W J	682,683					
427			689,695					
R419	OBT9707A	RK 18K 1/6W J	699,711					
R422	OBT9667A	RK 390 1/6W J	729,730					
R423,434	OBT9737A	RK 330K 1/6W J	733,735					
R424	OBT9729A	RK 150K 1/6W J	738					
R428	OBT9713A	RK 33K 1/6W J	R606,634	OBT1888A	RK 10K 1/4W J			
R429	OBT9719A	RK 56K 1/6W J	673,690					
R430	OBT5622A	RK 2.2K 1/4W J	724,728					
R432,433	OB09243A	RF 4.7 1/2W J	R618,697	OBT9707A	RK 18K 1/6W J			
C401	OB40037A	CE 10000μ 25V	698	OBT9713A	RK 33K 1/6W J			
C402	OB09374A	CE 6800μ 25V	R619,637					
C403,407	OBT1272A	CE 100μ 25V	638,642					
C404,408	OBT9276A	CC 5P 50V J	666,671					
C405	OB09798A	CE 6800μ 16V	691					
C406	OB09799A	CE 4700μ 25V	R620	OBT9717A	RK 47K 1/6W J			
C409,411	OB01397A	CE 1000μ 16V	R621	OBT9712A	RK 30K 1/6W J			
C410	OBT9218A	CE 47μ 16V (LN)	R622	OBT9716A	RK 43K 1/6W J			
C412	OB01406A	CE 2200μ 16V	R623,644	OBT9703A	RK 12K 1/6W J			
C413	OBT1405A	CE 1μ 50V	R624,645	OBT9723A	RK 82K 1/6W J			
C414	OBT9873A	CF 0.27μ 50V J	R625,668	OBT9727A	RK 120K 1/6W J			
	-- Logic --		R626,628	OBT9737A	RK 330K 1/6W J			
			633,652					
IC601	OB06324A	IC LM6402A-052	665,670					
IC602	OB06392A	IC LM6416E-149	674,678					
IC603	OB06124B	IC JRC4558D	679,680					
IC604	OB06317A	IC μPD4030BC	718,719					
IC605	OB06214A	IC μPD4071BC	725,732					
Q601,606	OBT6013A	TR 2SA733 (P,Q)	R630	OBT5620A	RK 270K 1/4W J			
607,611			R631	OBT5627A	RK 330K 1/4W J			
612,613			R635	OBT9699A	RK 8.2K 1/6W J			
614,621			R636,732	OBT9689A	RK 3.3K 1/6W J			
626,627			R640,653	OBT9709A	RK 22K 1/6W J			
629,630			R641	OBT9731A	RK 180K 1/6W J			
631,633			R643	OB22444Y	RM 76.8K 1/4W F			
635			R646	OB22457Y	RM 100K 1/4W F			
Q602,603	OBT1872A	TR 2SC945L (P,Q)	R647	OBT9305A	RM 100K 1/4W F			
604,605			R648,654	OBT5671A	RK 2.2M 1/4W J			
608,617			737					
618,619			R650	OBT9472A	RM 220K 1/4W F			
622,623			R655,656	OBT9315A	RM 332K 1/4W F			
628,632			R657	OB22420A	RM 47.5K 1/4W F			
634,636			R658	OB22475Y	RM 150K 1/4W F			
Q609	OB06316A	TR 2SD882 (P,Q)	R663	OBT5621A	RK 120K 1/4W J			
Q610	OB06303A	TR 2SB772 (P,Q)	R664	OBT5626A	RK 150K 1/4W J			
Q615	OB06066A	TR 2SD471 (L,M)	R669	OBT9729A	RK 150K 1/6W J			
Q616	OB06069A	TR 2SB564 (L,M)	R677,684	OBT1889A	RK 100K 1/4W J			
Q624,625	OBT6372A	TR 2SA953 (K,L)	685,686					
D601,612	OBT6181A	SID 1SS53	688,705					
613,620			714,715					
621,622			716,723					
625			R687	OBT9695A	RK 5.6K 1/6W J			
			R692	OBT9677A	RK 1K 1/6W J			
			R700	OBT9733A	RK 220K 1/6W J			
			R701,702	OBT9719A	RK 56K 1/6W J			
			707					

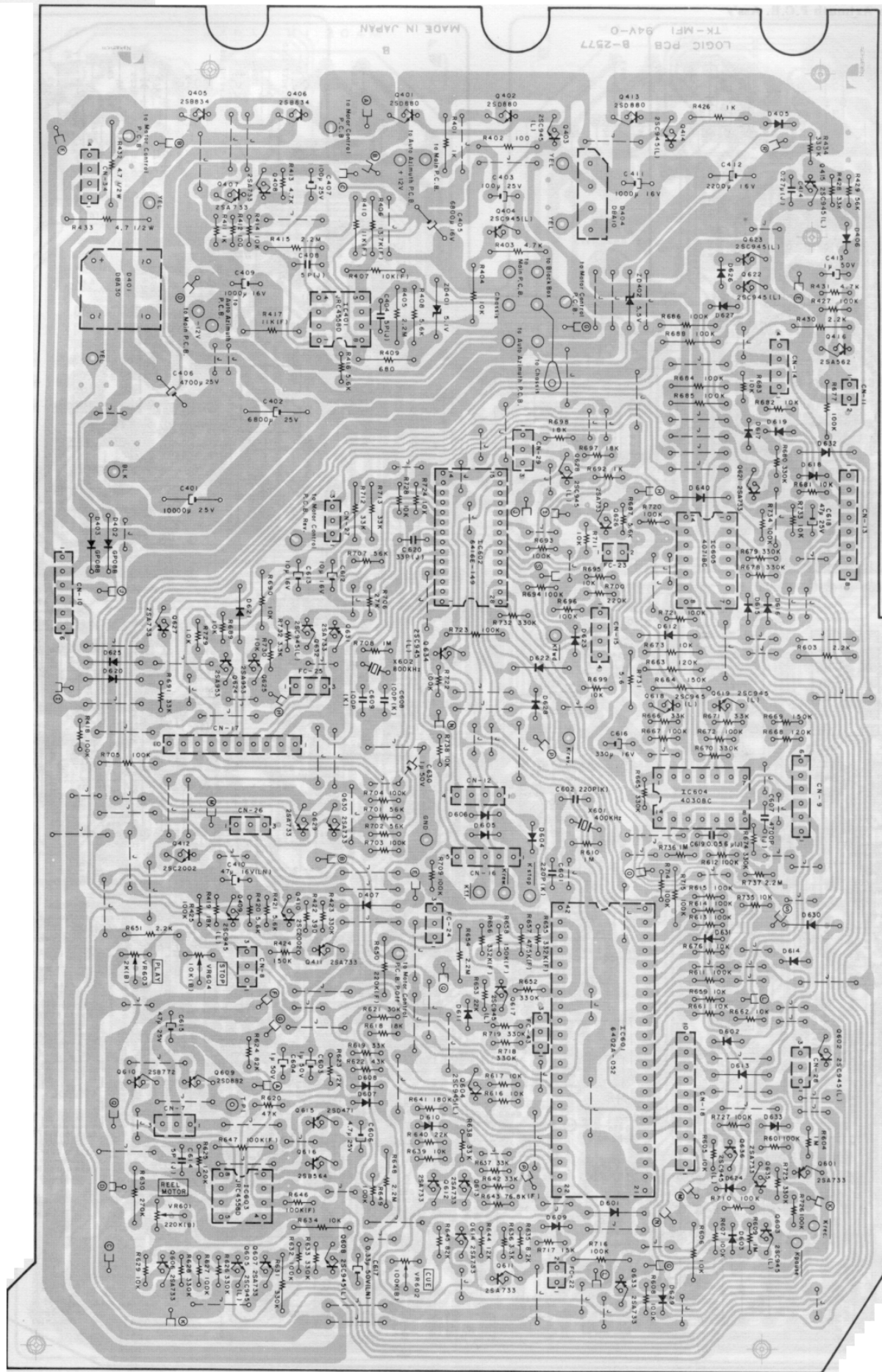

Fig. 6.14.1 Serial No.: A80102201 -

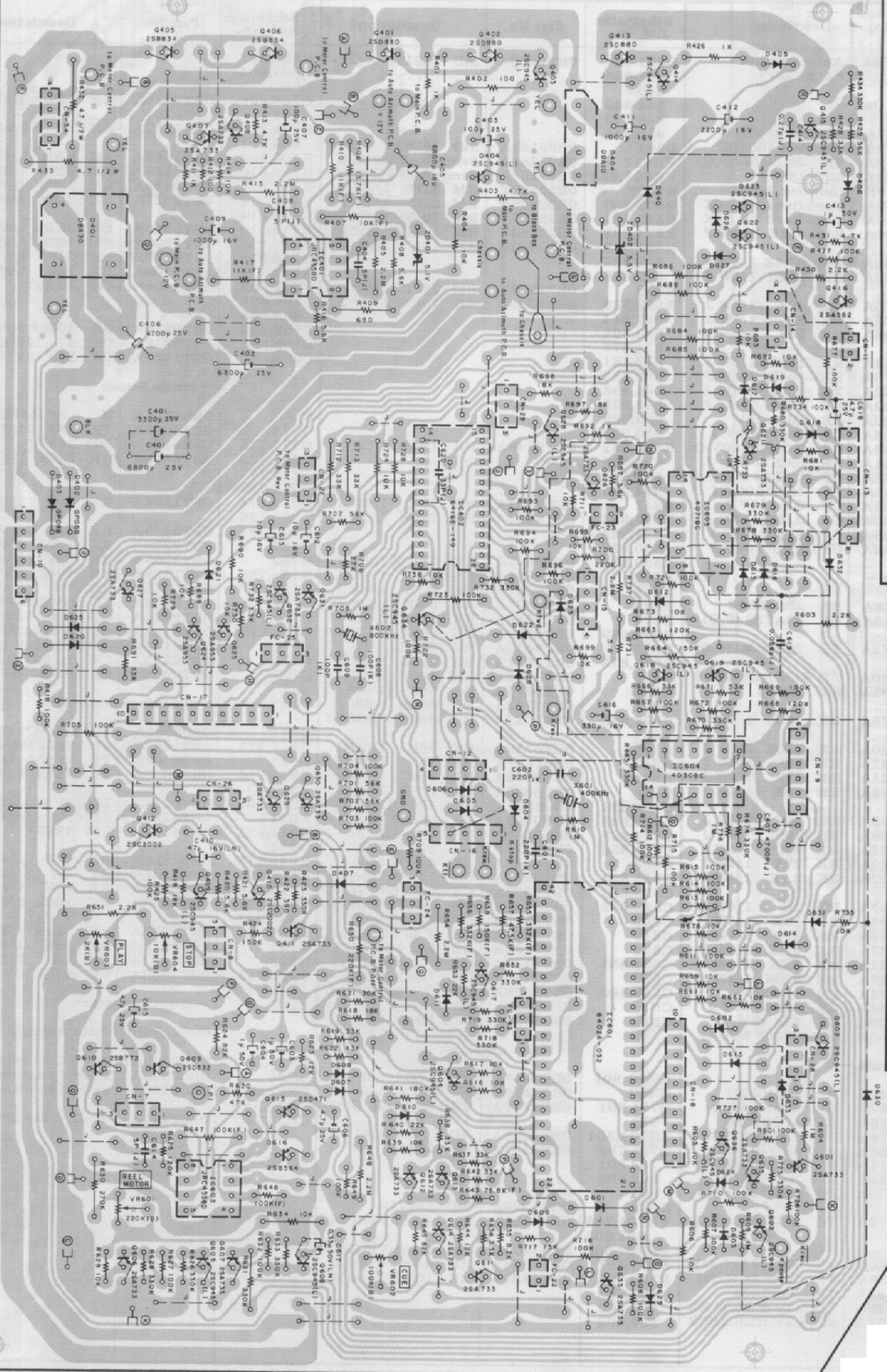

Fig. 6.14.2 Serial Nos.: A80101001 - A80102200

6.15. Auto Azimuth P.C.B. Assy

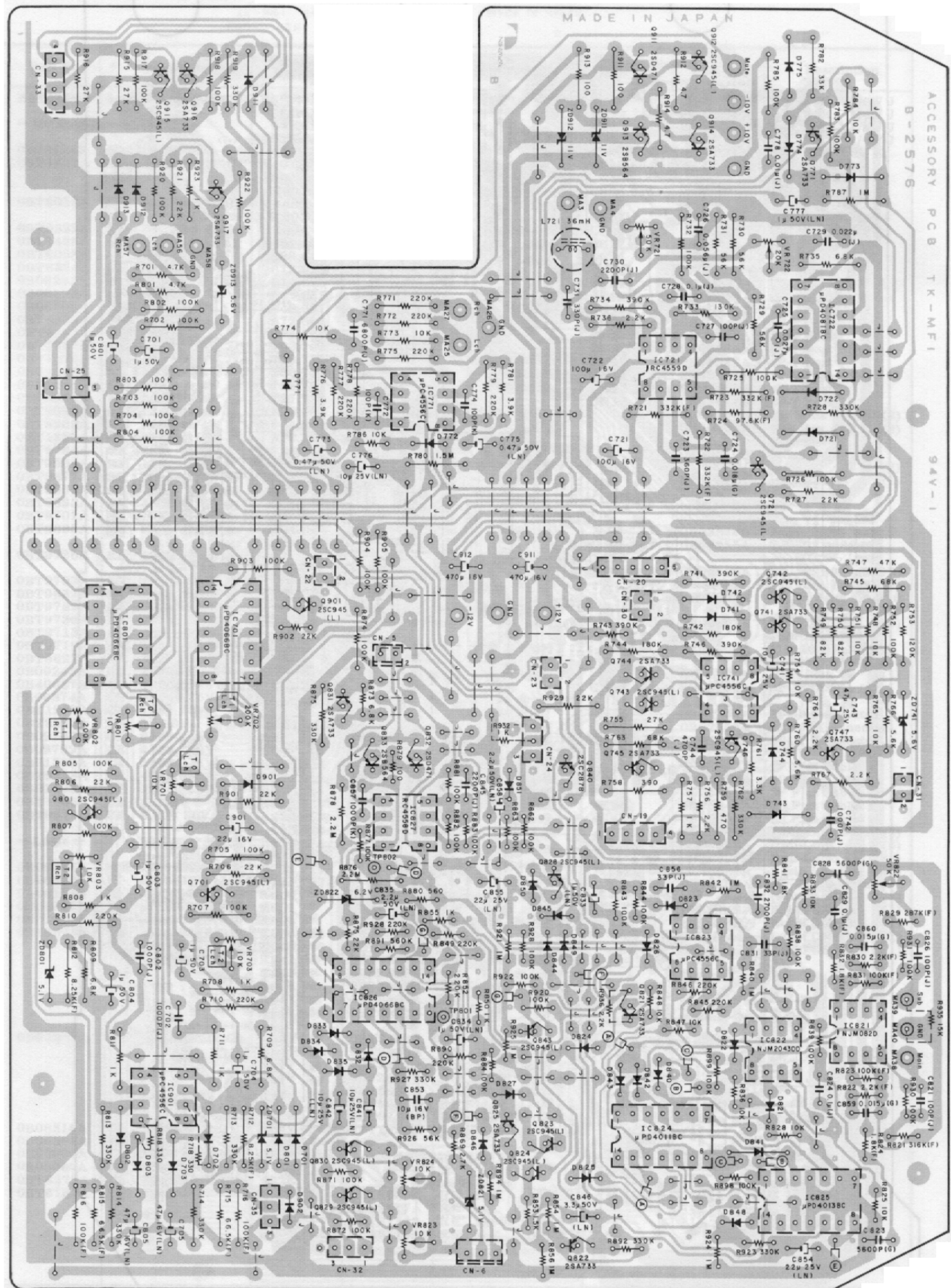

Fig. 6.15.1 Serial No.: A80102201

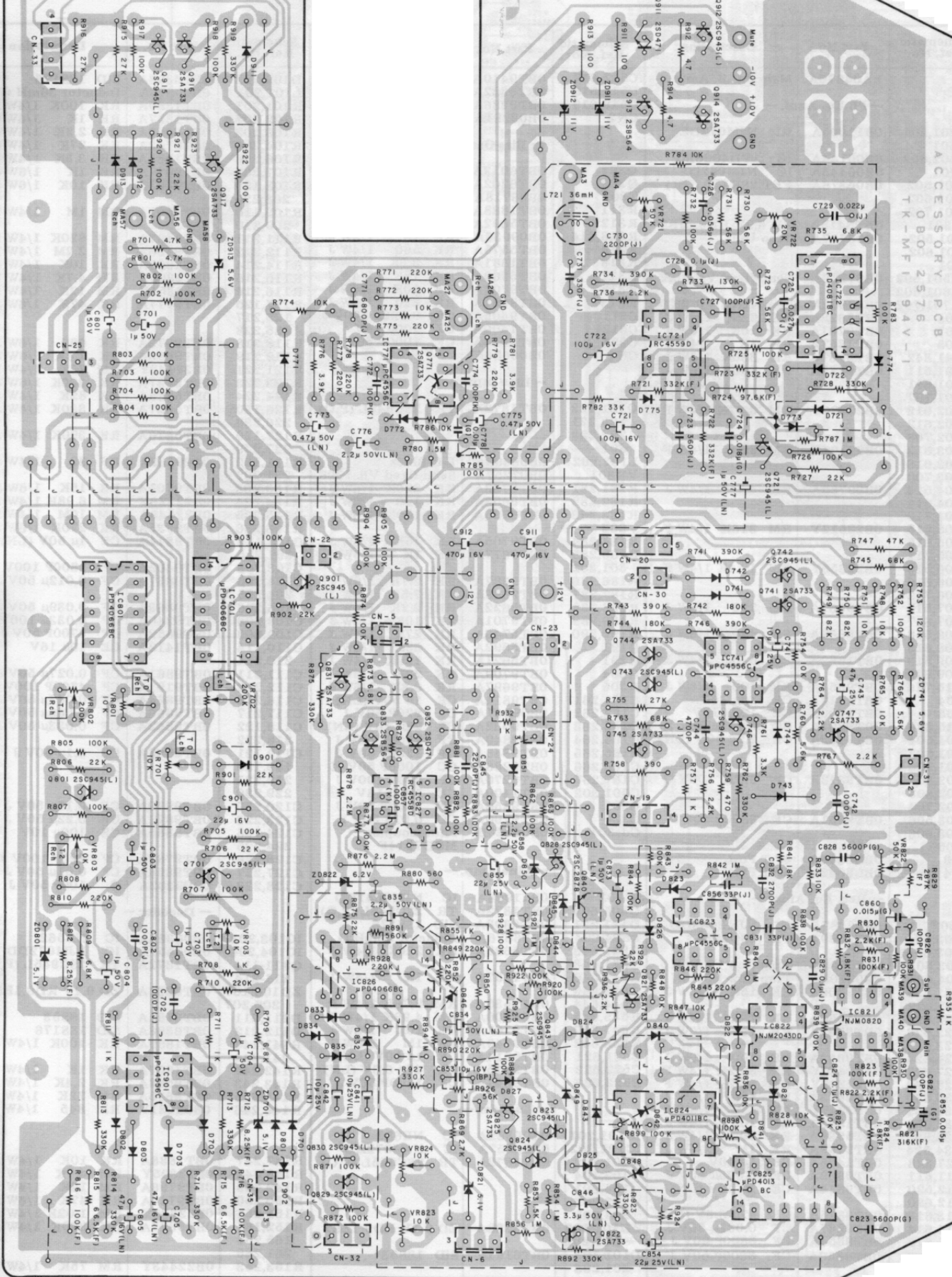

Fig. 6.15.2 Serial Nos.: A80101001 - A80102200

Schematic Ref. No.	Part No.	Description	Schematic Ref. No.	Part No.	Description	Schematic Ref. No.	Part No.	Description
	BA04870A	Main P.C.B. Ass'y	C517,617	OBT9410A	CP 2200P 100V G	D102,202	OBT6398A	SiD 1SS176
	- PB Eq. Amp. -		C518,618	OBT9322A	CP 330P 100V J	L101,201	OB06676A	Inductor 36mH G
			C519,619	OBT9286A	CC 470P 50V K	R101,201	OBT1889A	RK 100K 1/4W J
			CN2	OB02281A	4P-T Post	R102,202	OBT1857A	RK 1K 1/4W J
IC301,501	OB11005A	IC NJM072DE				R103,203	OBT5622A	RK 2.2K 1/4W J
601						R104,204	OBT5743A	RK 27K 1/4W J
IC502,602	OB06144A	IC μ PD4066BC	Q302	OBT6013A	TR 2SA733 (P,Q)	R106,206	OBT1681A	RK 3.3K 1/4W J
IC701	OB06443A	IC NJM082D	Q303	OBT6202A	TR 2SA562TM (Y)	R107,207	OBT9677A	RK 1K 1/6W J
Q501,502	OB06376A	FET 2SK170 (GR)	T301	OB06718A	Bias Osc. Unit	R108,120	OBT9701A	RK 10K 1/6W J
601,602			R311	OBT1888A		208,220		
701,702			R312	OBT5692A	RK 10K 1/4W J	R109,110	OBT9502A	RM 1M 1/4W F
ZD301	OBT6418A	ZD 8.2V RD8.2JB2	R313,314	OB09936A	RF 10 1/2W J	R111,211	OBT9197A	RM 820K 1/4W F
L501,502	OB06717A	Trap Unit	R315	OBT5575A	RK 560 1/4W J	R112,212	OBT9766A	RM 2.2M 1/4W F
601,602			R316	OBT1681A	RK 3.3K 1/4W J	R114,214	OBT1888A	RK 10K 1/4W J
VR501,502	OB07256A	Semi-fixed VR 10K	R317	OBT5560A	RK 18K 1/4W J	R115,215	OB22305Y	RM 4.7K 1/4W F
601,602			R318	OBT9701A	RK 10K 1/6W J	R116,216	OB22351Y	RM 12K 1/4W F
VR701,702	OB32002A	Semi-fixed VR 2K	R343	OBT9661A	RK 220 1/6W J	R117,125	OBT9717A	RK 47K 1/6W J
R306	OBT5622A	RK 2.2K 1/4W J	C311	OBT9405A	CP 0.022 μ 100V J	128,217		
R307	OBT9701A	RK 10K 1/6W J	C312	OBT1400A	CE 100 μ 16V	225,228		
R308	OBT1857A	RK 1K 1/4W J	C321	OBT9844A	CF 1000P 50V J	R118,218	OBT9673A	RK 680 1/6W J
R341,342	OBT9737A	RK 330K 1/6W J	CN1	OB08656A	2P-T Post	R119,219	OBT9683A	RK 1.8K 1/6W J
R501,511	OBT9725A	RK 100K 1/6W J				R121,221	OB22443Y	RM 75K 1/4W F
601,611						R123,223	OBT9737A	RK 330K 1/6W J
701,707						R124,224	OBT5668A	RK 82K 1/4W J
R502,512	OB22296Y	RM 3.92K 1/4W F	Q121,122	OBT1872A	TR 2SC945L (P,Q)	R126,130	OBT5627A	RK 330K 1/4W J
602,612			123,221			226,230		
702,708			222,223			R127,129	OBT5676A	RK 390K 1/4W J
R503,513	OB22104Y	RM 80.6 1/4W F	301			227,229		
603,613			L102,202	OB06690A	L-C Block	R131,132	OB09162A	RF 82 1/4W J
703,709			VR301	OB07257A	Semi-fixed VR 100K	231,232		
R504,514	OB09785A	RK 4.7M 1/4W J	R181,281	OBT9733A	RK 220K 1/6W J	R133,233	OBT9705A	RK 15K 1/6W J
604,614			R182,282	OBT9653A	RK 100 1/6W J	R134,234	OB22326Y	RM 6.98K 1/4W F
704,710			R183,283	OBT9725A	RK 100K 1/6W J	R135,235	OB22545A	RM 10M 1/4W F
R505,515	OB22512Y	RM 316K 1/4W F	303			R136,236	OBT9735A	RK 270K 1/6W J
605,615			R184,284	OBT9705A	RK 15K 1/6W J	C101,115	OBT9814A	CE 1 μ 50V (LN)
705,711			R185,285	OBT9677A	RK 1K 1/6W J	201,215		
R506,516	OB22353Y	RM 12.4K 1/4W F	301,302			C103,203	OBT9409A	CF 1800P 100V G
606,616			R186,286	OBT9687A	RK 2.7K 1/6W J	C104,105	OBT9857A	CF 0.012 μ 50V J
706,712			R187,287	OBT9698A	RK 7.5K 1/6W J	204,205		
R507,517	OBT9661A	RK 220 1/6W J	R188,288	OBT5622A	RK 2.2K 1/4W J	C106,206	OBT9863A	CF 0.039 μ 50V J
607,617			R189,289	OBT9701A	RK 10K 1/6W J	C108,208	OBT9240A	CF 0.033 μ 100V G
R508,518	OBT9669A	RK 470 1/6W J	R190,290	OBT5743A	RK 27K 1/4W J	C109,209	OBT9852A	CF 4700P 50V J
608,618			R191	OBT5692A	RK 68K 1/4W J	C110,114	OBT1412A	CE 10 μ 16V
R509,519	OBT1682A	RK 6.8K 1/4W J	R291	OBT5621A	RK 120K 1/4W J	210,214		
609,619			R304	OBT9709A	RK 22K 1/6W J	C111,211	OBT9861A	CF 0.027 μ 50V J
R715,716	OBT9653A	RK 100 1/6W J	R305	OBT9697A	RK 6.8K 1/6W J	C112,212	OBT9191A	CF 4700P 100V G
C304	OBT1412A	CE 10 μ 16V	C161,261	OBT9814A	CE 1 μ 50V (LN)	C116,216	OBT9864A	CF 0.047 μ 50V J
C305	OBT1400A	CE 100 μ 16V	C162,262	OB09247A	C 220P 50V J	C117,217	OBT9866A	CF 0.068 μ 50V J
C325,326	OBT9291A	CC 0.022 μ 50V Z	C163,263	OBT9932A	CE 22 μ 16V (LN)	C118,122	OBT9862A	CF 0.033 μ 50V J
C501,504	OBT9933A	CE 2.2 μ 50V (LN)	C164,264	OBT9849A	CF 2700P 50V J	218,222		
601,604			C165,265	OBT9845A	CF 1200P 50V J	C119,121	OBT9868A	CF 0.1 μ 50V J
701,703			C166,266	OBT9288A	CC 1000P 50V K	129,130		
C502,505	OBT9312A	CP 0.01 μ 100V G	C167,267	OBT9270A	CP 470P 100V J	219,221		
602,605			C301,302	OBT1400A	CE 100 μ 16V	229,230		
702,704			C303	OBT9850A	CF 3300P 50V J	C120,220	OBT9870A	CF 0.15 μ 50V J
C503,506	OBT9851A	CF 3900P 50V J	C320	OBT9290A	CC 0.01 μ 50V Z	C123,223	OBT9872A	CF 0.22 μ 50V J
603,606			Cds301	OB06325B	Photocoupler MCD7214F	C124,125	OBT5885A	CE 100 μ 10V
705						224,225		
CN3	OBL8654A	4P-T Post				C126,226	OBT9783A	CF 820P 100V J
CN4	OBL8642A	6P-T Post				C127,227	OBT9856A	CF 0.01 μ 50V J
	- Rec. Eq. Amp. -					C128,228	OB09302A	C 100P 50V J
IC302	OB06387A	IC NJM2043DD	IC303	OB11004A	IC NJM2041DD		- Decoder -	
Q503,504	OBT6299A	TR 2SC2878	Q505,605	OBT1872A	TR 2SC945L (P,Q)		OB06382A	IC NE562
603,604			D121,221	OBT6398A	SiD 1SS176		OB06457A	IC NJM072DD
L503,603	OB00068A	Trap Coil 10.5mH	L504,604	OB06676A	Inductor 36mH G	IC103,203	OBT1872A	TR 2SC945L (P,Q)
L504,604	OB06705A	Trap Coil 1.05mH	R541,543	OBT5625A	RK 220K 1/4W J	IC104,204		
R521,529	OBT9705A	RK 15K 1/6W J	641,643			Q111-114		
621,629			R542,546	OBT1857A	RK 1K 1/4W J	211-214		
R522,622	OBT5560A	RK 18K 1/4W J	642,646			ZD106,107	OBT6232A	ZD 9.1V RD9.1EB2
R523,526	OBT9731A	RK 180K 1/6W J	R544,644	OBT9535A	RM 9.76K 1/4W F	206,207		
623,626			R545,645	OBT9900A	RM 4.99K 1/4W F	D111,211	OBT6181A	SiD 1SS53
R524,624	OBT9653A	RK 100 1/6W J	R547,647	OBT9701A	RK 10K 1/6W J	D112,212	OBT6398A	SiD 1SS176
R527,627	OB22410Y	RM 39.2K 1/4W F	R548,648	OBT9749A	RK 1M 1/6W J	R141,144	OBT1889A	RK 100K 1/4W J
R528,628	OB22296Y	RM 3.92K 1/4W F	C521,621	OBT9814A	CE 1 μ 50V (LN)	241,244		
R530,630	OBT9673A	RK 680 1/6W J	C522,622	OBT9815A	CE 4 μ 6.3V (LN)	R142,242	OBT1857A	RK 1K 1/4W J
R531,631	OB22247Y	RM 1.5K 1/4W F	C523,623	OBT9847A	CF 1800P 50V J	R143,243	OBT9588A	RK 2.4K 1/4W J
R532,632	OBT1888A	RK 10K 1/4W J				R145,245	OBT5615A	RK 22K 1/4W J
R533,633	OBT5936A	RK 10 1/4W J	IC101,201			R146,246	OB22221Y	RM 845 1/4W F
R534,634	OBT9749A	RK 1M 1/4W J	IC102,202	OB06382A	IC NE652			
C327,328	OBT1405A	CE 1 μ 50V	Q101,102	OB06457A	IC NJM072DD			
C511,611	OBT9862A	CF 0.033 μ 50V J	103,104	OBT1872A	TR 2SC945L (P,Q)	R147,247	OBT1888A	RK 10K 1/4W J
C512,520	OBT9814A	CE 1 μ 50V (LN)	105,201			R148,248	OB22305Y	RM 4.7K 1/4W F
612,620			202,203			R149,249	OBT9796A	RM 12K 1/4W F
C513,613	OBT9815A	CE 47 μ 6.3V (LN)	204,205			R150,250	OBT9717A	RK 47K 1/6W J
C514,614	OBT9867A	CF 0.082 μ 50V J	ZD101,102	OBT6232A	ZD 9.1V RD9.1EB2	R151,251	OB22230Y	RM 1.02K 1/4W F
C515,615	OBT9854A	CF 6800P 50V J	201,202			R152,161	OBT5627A	RK 330K 1/4W J
C516,616	OBT9850A	CF 3300P 50V J	D101,103	OBT6181A	SiD 1SS53	165,252		
			201,203			261,265		
						R153,253	OB22443Y	RM 75K 1/4W F

Schematic Ref. No.	Part No.	Description
R155,255	OBT9685A	RK 2.2K 1/6W J
R156,256	OBT9713A	RK 33K 1/6W J
R157,257	OBT9693A	RK 4.7K 1/6W J
R158,258	OBT9701A	RK 10K 1/6W J
R159,163	OBT5641A	RK 47K 1/4W J
259,263		
R160,260	OBT5668A	RK 82K 1/4W J
R162,164	OBT5676A	RK 390K 1/4W J
262,264		
R166,167	OB09162A	RF 82 1/4W J
266,267		
R168,268	OBT9749A	RK 1M 1/6W J
C131,231	OBT9933A	CE 2.2 μ 50V (LN)
C133,233	OBT9852A	CF 4700P 50V J
C134,234	OBT9240A	CP 0.033 μ 100V G
C135,140	OBT1412A	CE 10 μ 16V
235,240		
329		
C136,144	OBT9866A	CF 0.068 μ 50V J
236,244		
C137,237	OBT9814A	CE 1 μ 50V (LN)
C139,239	OB09191A	CP 4700P 100V G
C141,241	OBT9286A	CC 470P 50V K
C142,242	OBT9856A	CF 0.01 μ 50V J
C143,243	OBT9864A	CF 0.047 μ 50V J
C145,149	OBT9862A	CF 0.033 μ 50V J
245,249		
C146,148	OBT9868A	CF 0.1 μ 50V J
246,248		
C147,247	OBT9870A	CF 0.15 μ 50V J
C150,250	OBT9872A	CF 0.22 μ 50V J
C151,152	OBT5885A	CE 100 μ 10V
251,252		
C153,253	OB09302A	C 100P 50V J
C154,254	OBT9262A	CP 3000P 100V J
C310	OBT1405A	CE 1 μ 50V
-- Logic Interface --		
Q304,307	OBT1872A	TR 2SC945L (P,Q)
308		
Q305,306	OBT6013A	TR 2SA733 (P,Q)
D301,302	OBT6181A	SID 1SS53
304,305		
313,314		
D303,311	OBT6398A	SID 1SS176
312		
R318,320	OBT1889A	RK 100K 1/4W J
322,326		
R319	OBT5509A	RK 33K 1/4W J
R321,331	OBT5641A	RK 47K 1/4W J
332		
R323	OBT1888A	RK 10K 1/4W J
R324	OBT5743A	RK 27K 1/4W J
R325	OBT1857A	RK 1K 1/4W J
R327	OBT9717A	RK 47K 1/6W J
R328	OBT5675A	RK 560 1/4W J
R333,334	OBT9749A	RK 1M 1/6W J
C313,314	OB01406A	CE 2200 μ 16V
C322,323	OBT9292A	CC 0.1 μ 50V Z
324		
-- Headphone Amp. --		
IC304	OB06217A	IC NJM4560D
Q506,606	OB06066A	TR 2SD471 (L,M)
Q507,607	OB06069A	TR 2SB564 (L,M)
R551,651	OBT9653A	RK 100 1/6W J
R552,553	OBT1889A	RK 100K 1/4W J
652,653		
R554,654	OBT9645A	RK 47 1/6W J
R555,655	OB09331A	RF 8.2 1/4W J
C531,631	OBT9277A	CC 10P 50V J
C315,316	OBT1405A	CE 1 μ 50V
-- Miscellaneous --		
CN21,37	OB02575B	Main P.C.B.
CN36	OB02348A	3P-JP Connector
FC21	OB02350A	5P-JP Connector
FC30	OB05343B	3P Flat Cable
FC31	OB05334B	2P Flat Cable
FC32,47	OB82032A	2P Flat Cable
FC33	OB05342B	3P Flat Cable
FC37	OB05356B	4P Flat Cable
FC46	OB05341B	3P Flat Cable
FC48	OB05344B	3P Flat Cable
FC49	OB05347B	3P Flat Cable
	OB05335B	2P Flat Cable
	OB08515A	Insu-Lock (5)

Schematic Ref. No.	Part No.	Description
	OB08676B	Heat Sink A304 (1)
	OM04238A	Label CN-26 (1)
	OM04239A	Label CN-27 (1)
	OM04439A	Label CN-30 (1)
	OM04247A	Label CN-31 (1)
	OM04248A	Label CN-32 (1)
	OM04249A	Label CN-33 (1)
	OE00612A	M3x6 \oplus Pan (2A) (2)
	OE00857A	BT 3x6 \oplus Binding (Chromate) (2)
	OJ03834C	Fuse P.C.B. Holder (1)

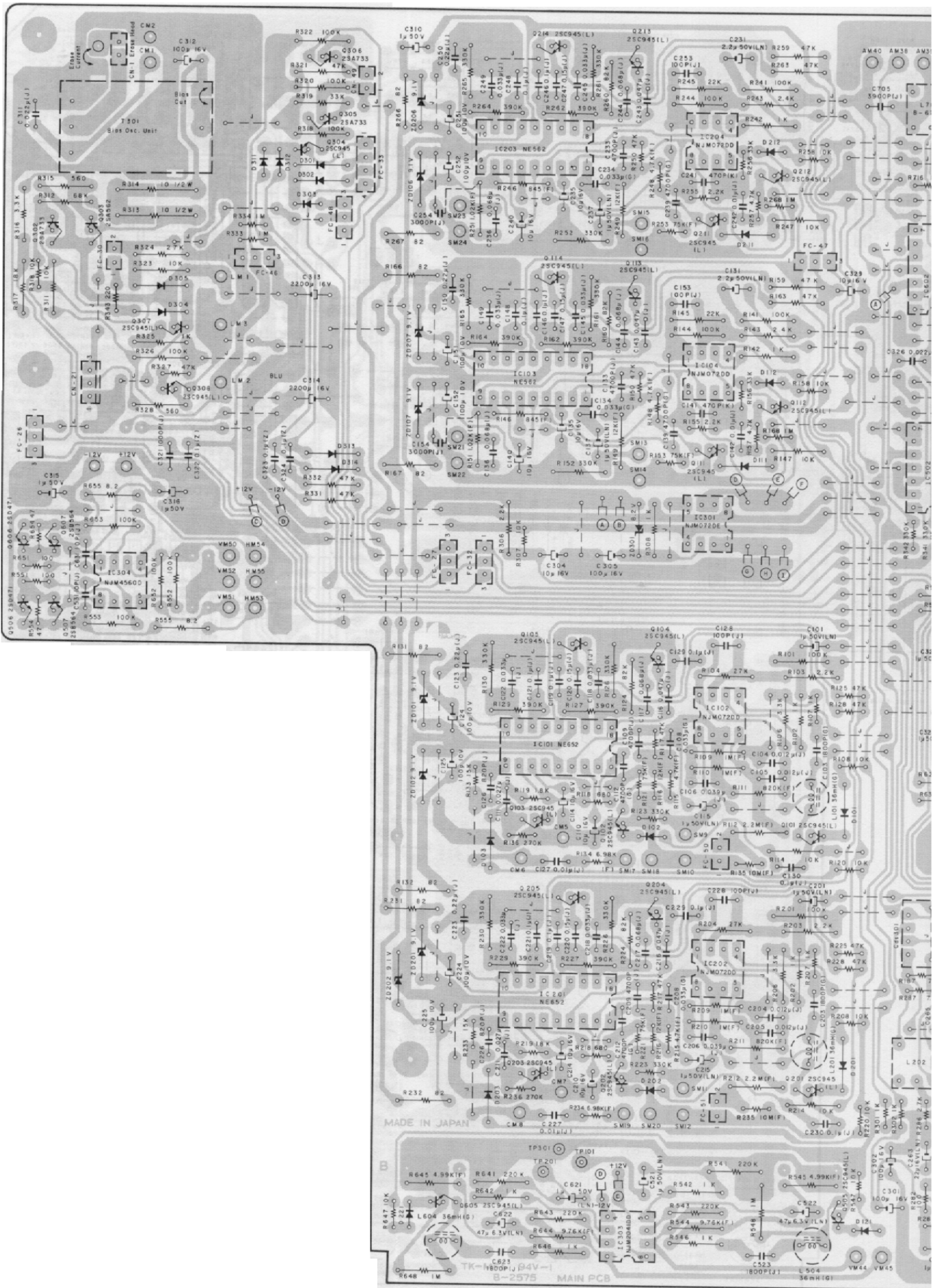

Fig. 6.16.1 Serial No.: A80102201 -

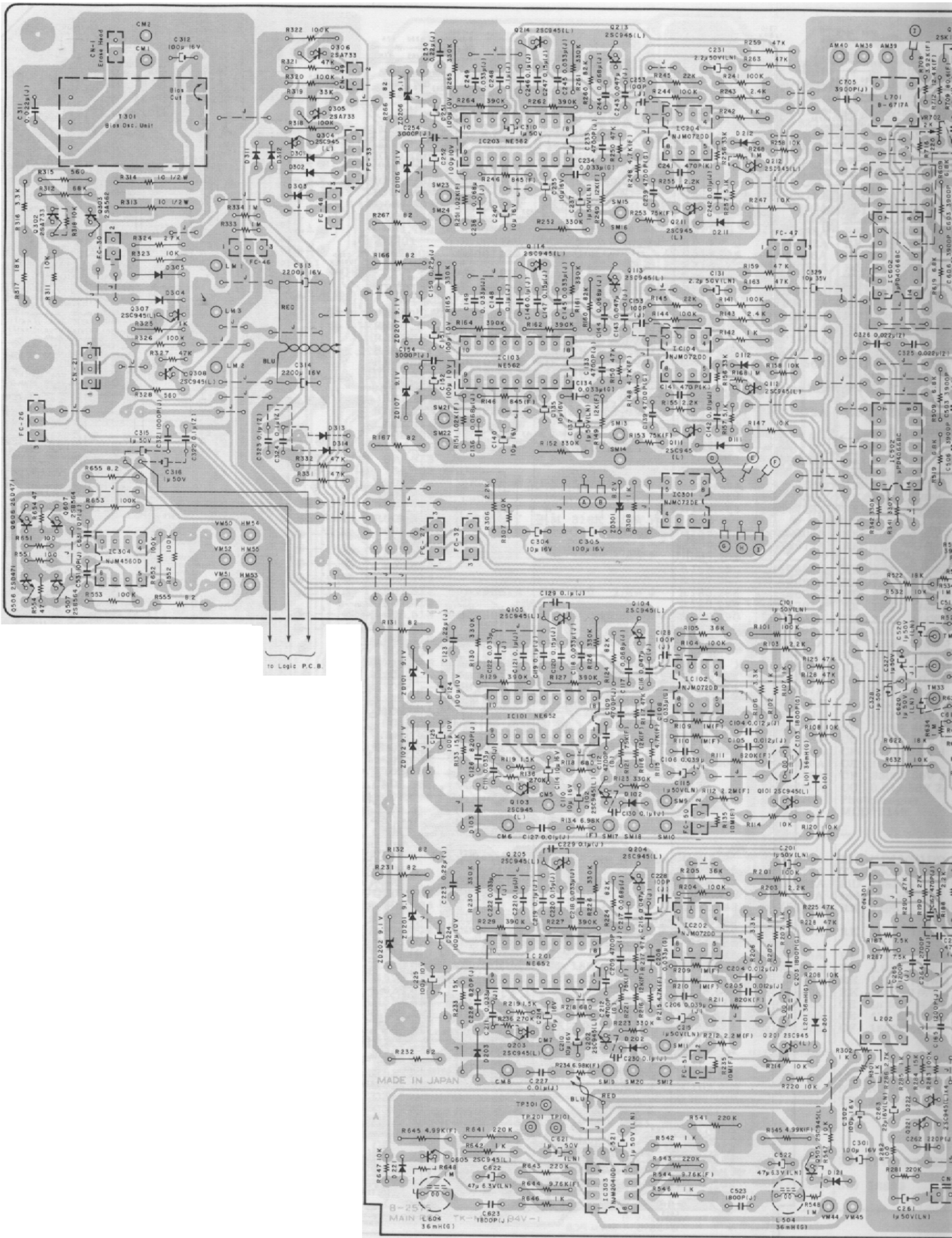
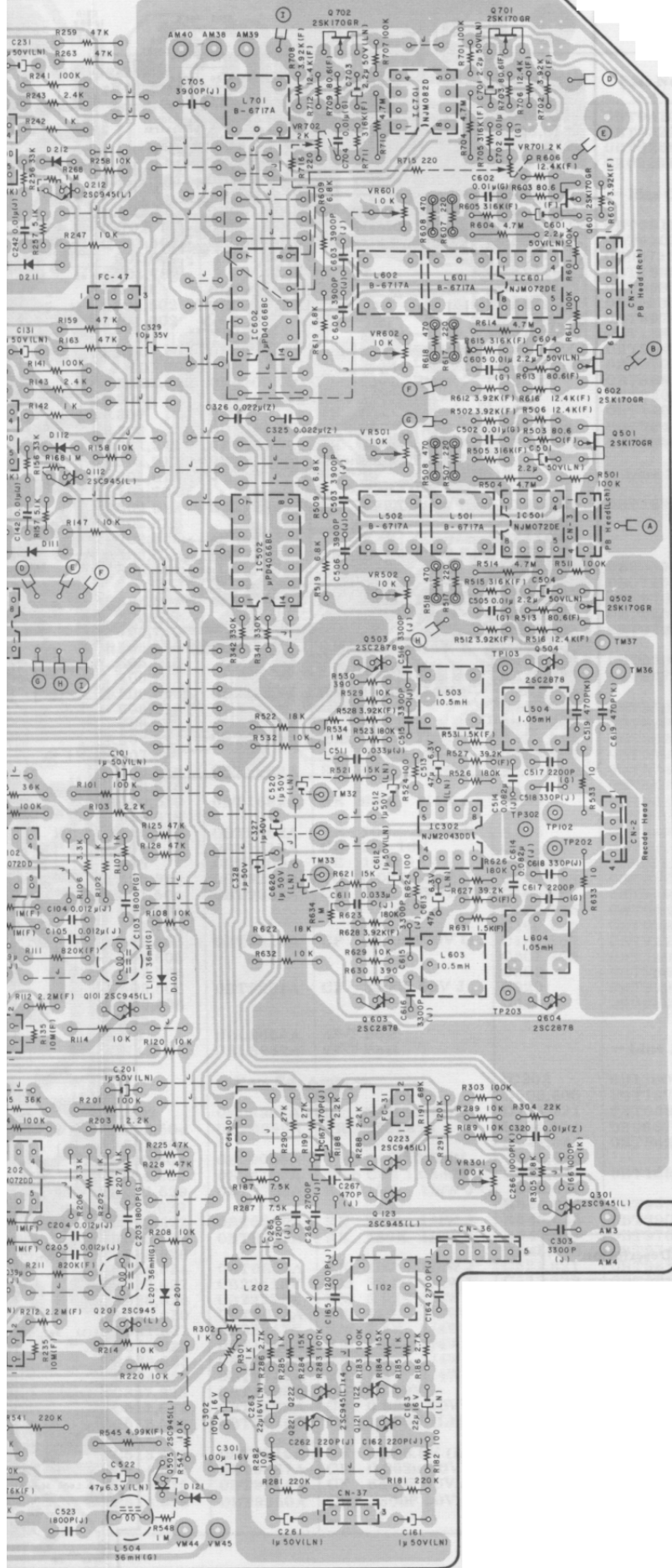

Fig. 6.16.2 Serial Nos.: A80101001 - A80102200



7.1. Attention to Servicemen

(1) Parts Replacement

Following parts shall be replaced with the specified ones. Refer to the parts list.

(a) Power Supply Circuit

- Power Cord
- Power Transformer: T1

(b) Power Switch P.C.B. Ass'y

- Power Switch: SW1
- Spark Killer: M2

(c) Fuse P.C.B. Ass'y

- Fuses: F01, 02, 03

(d) Logic P.C.B. Ass'y

- Power Transistors: Q401, 402, 405, 406, 410, 412, 413, 416, 609, 610, 615, 616
- Diode Bridges: D401, 404
- Fail Safe Type Resistors: R432, 433, 731

(e) Main P.C.B. Ass'y

- Power Transistors: Q303, 506, 606
- Fail Safe Type Resistors: R131, 132, 166, 167, 231, 232, 266, 267, 313, 314, 555, 655

(f) Auto Azimuth P.C.B. Ass'y

- Power Transistors: Q832, 833, 911, 913
- Fail Safe Type Resistors: R911, 912, 913, 914

(g) Motor Control P.C.B. Ass'y

- Power Transistors: Q518, 519, 520, 521, 522, 523, 524, 525, 526
- Fail Safe Type Resistors: R572, 573, 582, 583

(h) Shut-off P.C.B. Ass'y

- Fail Safe Type Resistor: R605
- Lamp: PL602

(i) Counter Pulse Generator P.C.B. Ass'y

- Fail Safe Type Resistor: R601
- Lamp: PL601

(2) Insulation Check

Before returning the repaired Nakamichi DRAGON to a customer, check to insure that the exposed parts are accurately insulated from the AC line by measuring the leakage current or the insulation resistance between them.

2. IC Block Diagrams

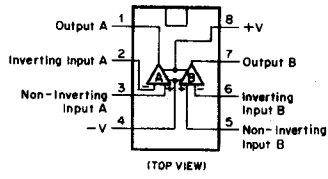

Fig. 7.2.1 Operational Amp. IC 4558D, 4559D, 4560D, 4556C, 2041DD, 2043DD, 082D, 072D

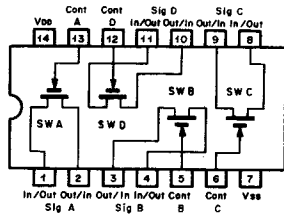

Fig. 7.2.2 Bilateral Switch C-MOS IC μPD4066BC

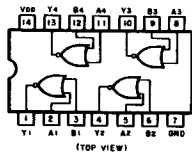

Fig. 7.2.3 NOR Gate C²-MOS IC TC40H002P

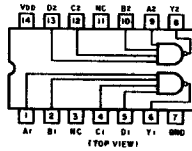

Fig. 7.2.4 NAND Gate C²-MOS IC TC40H020P

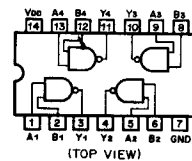

Fig. 7.2.5 NAND Gate C-MOS IC μPD4011BC

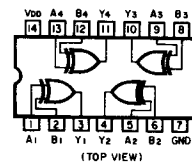

Fig. 7.2.6 Exclusive OR Gate C-MOD IC μPD4030BC

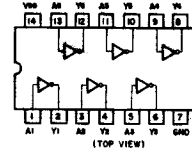

Fig. 7.2.7 Inverter C-MOS IC TC4069UBP

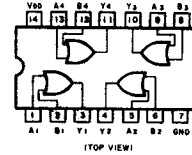

Fig. 7.2.8 OR Gate C-MOS IC μPD4071BC

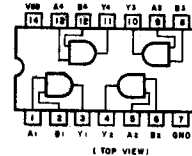

Fig. 7.2.9 AND Gate C-MOS IC μPD4081BC

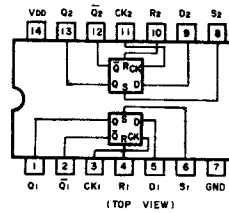

Fig. 7.2.10 D-Type Flip-Flop C-MOS IC μPD4013BC

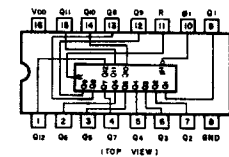

Fig. 7.2.11 Decoder C-MOS IC μPD4040BC

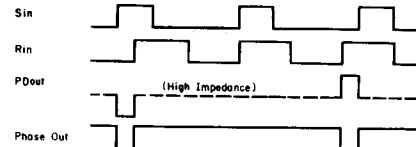
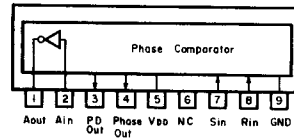
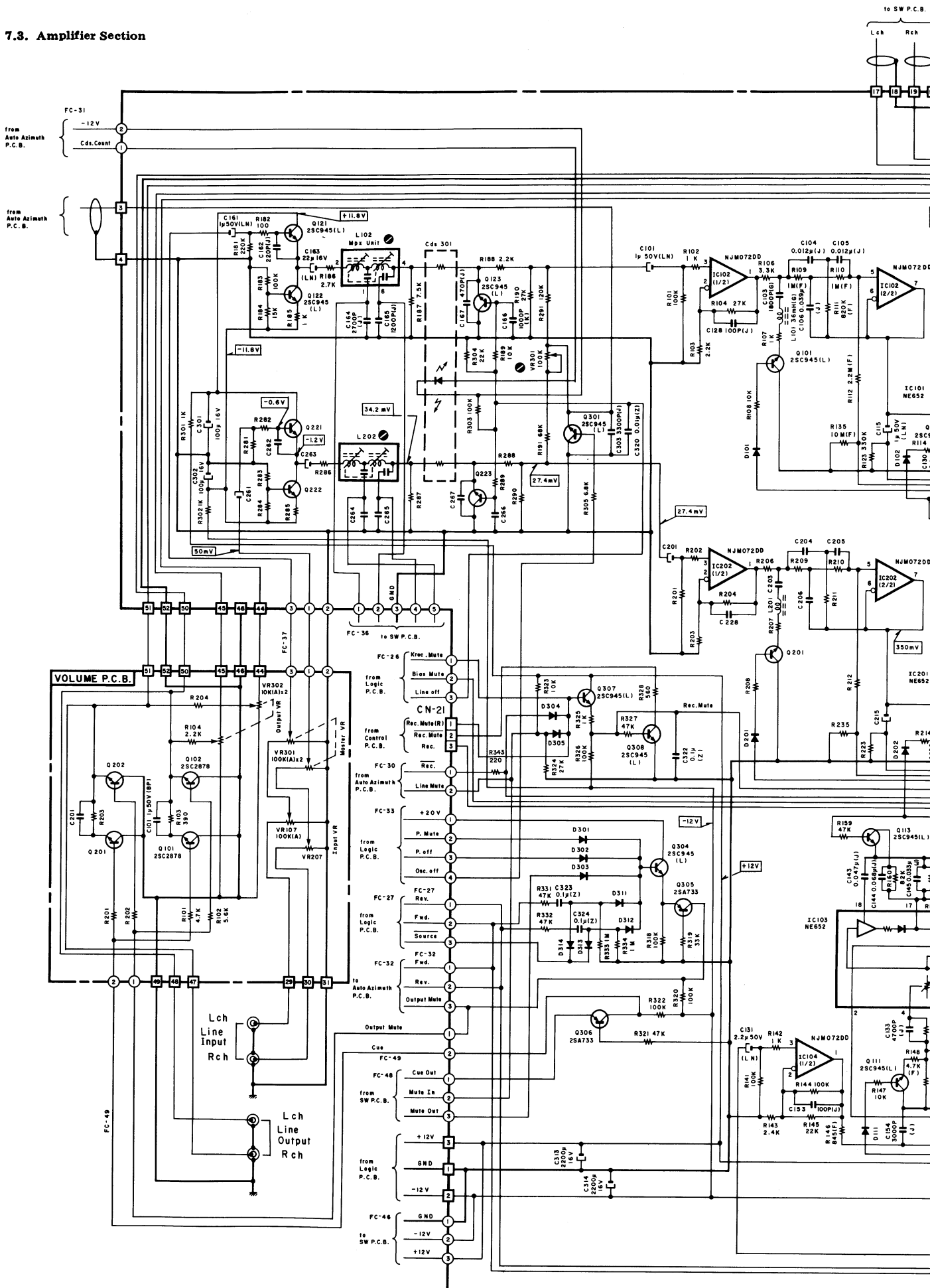

Fig. 7.2.12 Phase Comparator TC5081P

7.3. Amplifier Section



- Notes: 1. Diode is 1SS53, 1S1555, or 1SS176 unless otherwise specified.
 2. Resistor and capacitor marked with * show typical value.

- Notes: 1. 2SA733, 2SA608SP, 2SA1048 and 2SA1175 are interchangeable with each other.
 2. 2SC945, 2SC536SP, 2SC2458 and 2SC2785 are interchangeable with each other.

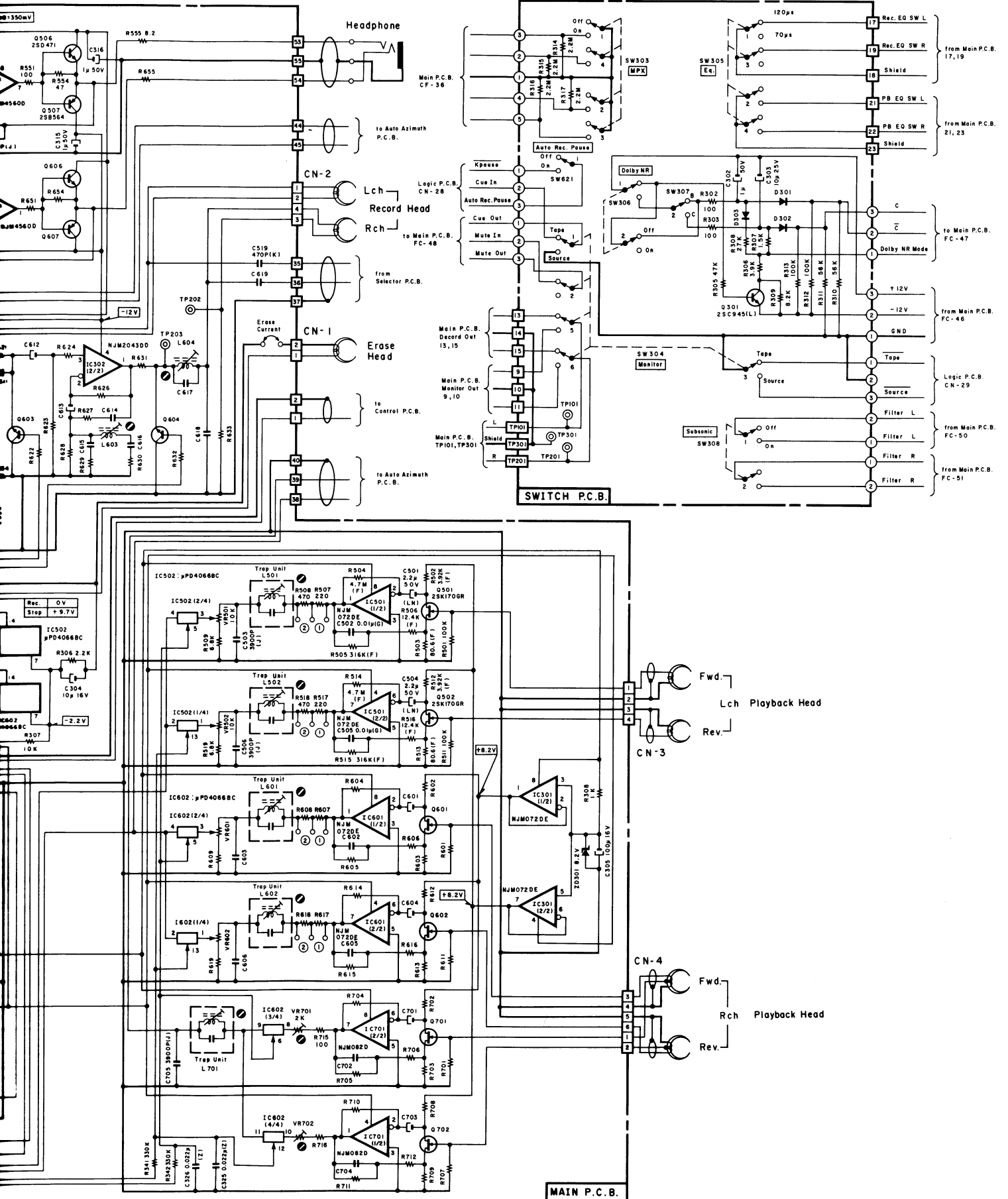

7.4. Auto Azimuth Control Section

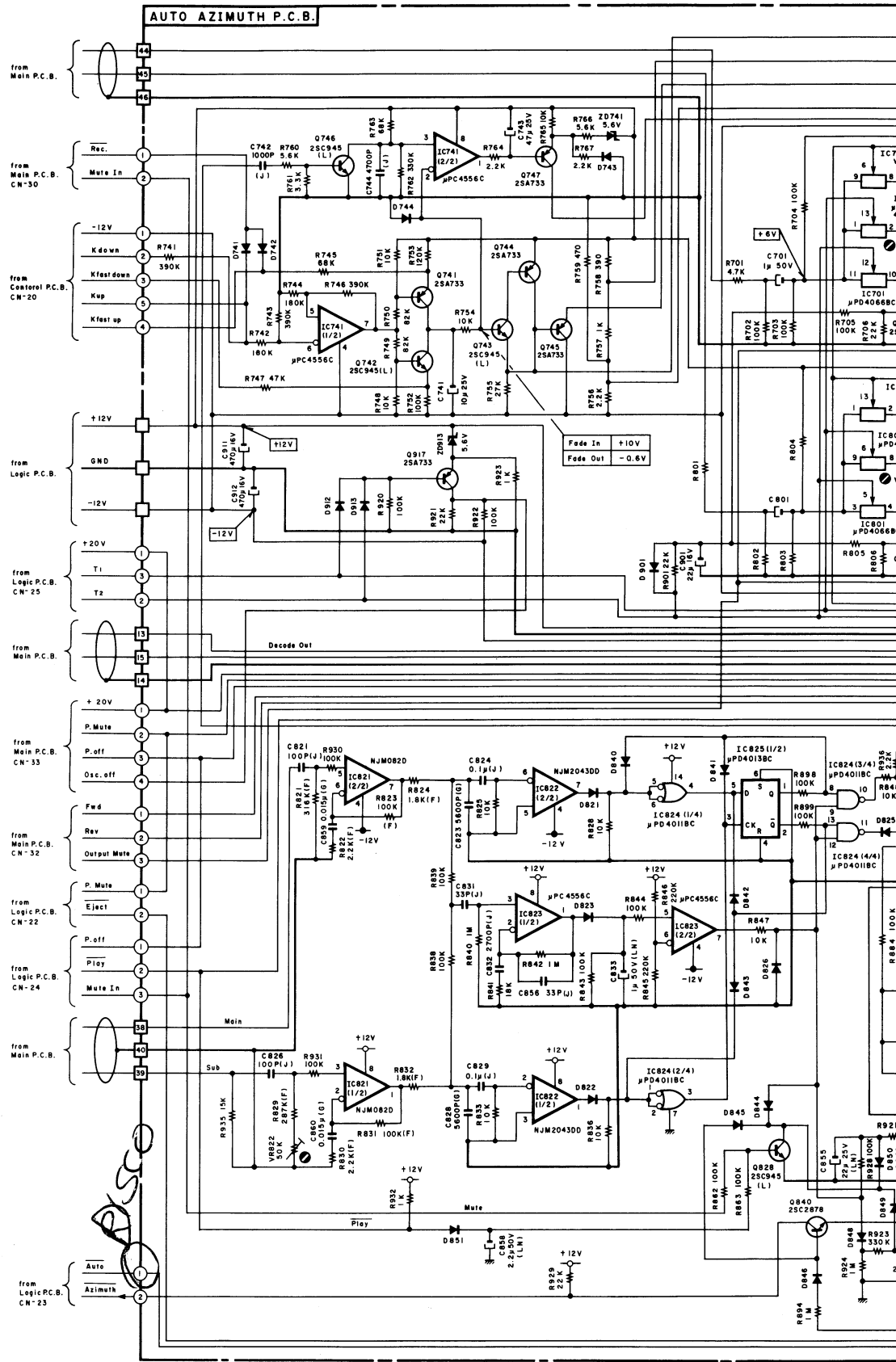

- Notes: 1. 2SA733, 2SA6085P, 2SA1048 and 2SA1175 are interchangeable
 2. 2SC945, 2SC5365P, 2SC2458 and 2SC2785 are interchangeable

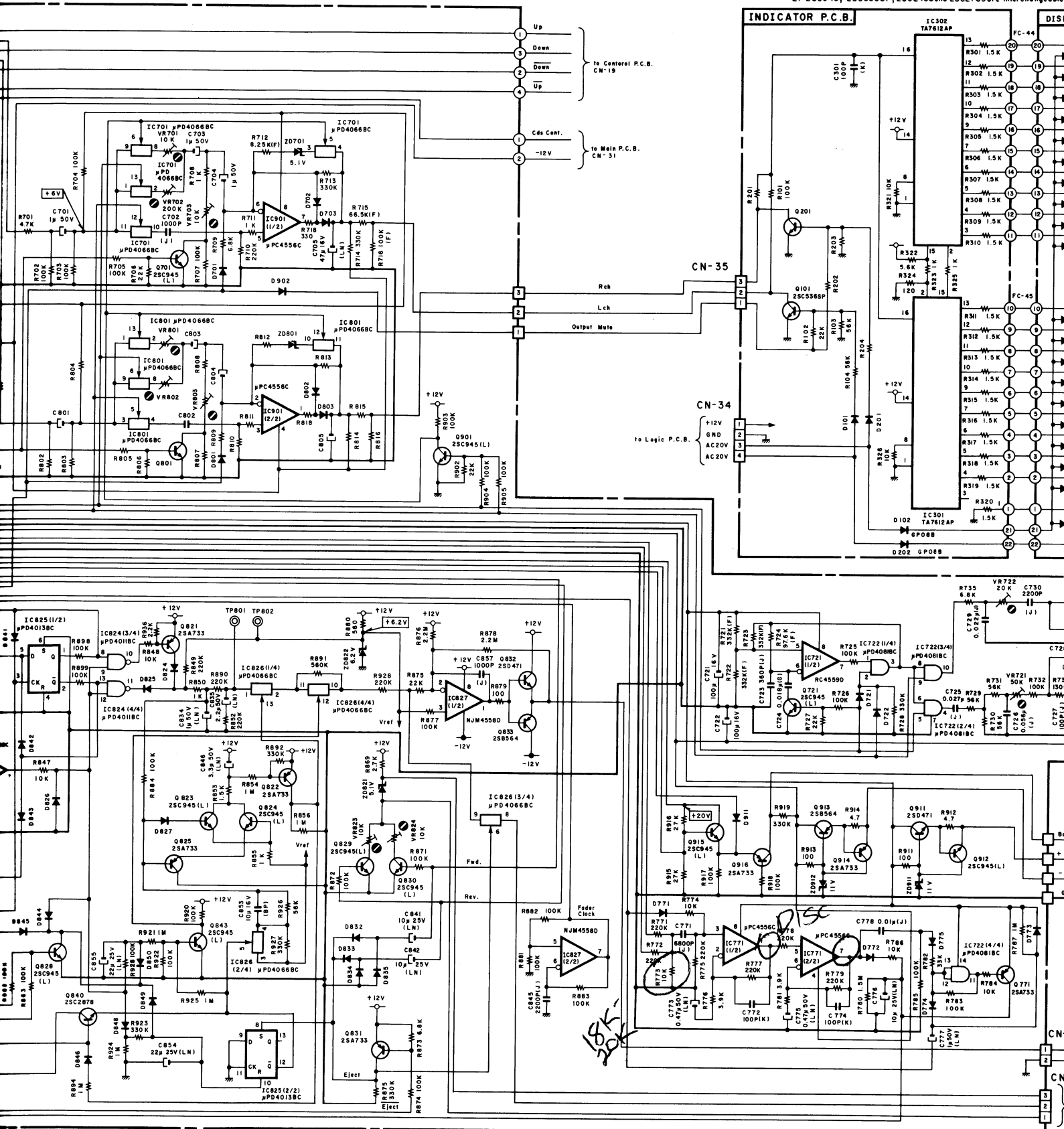
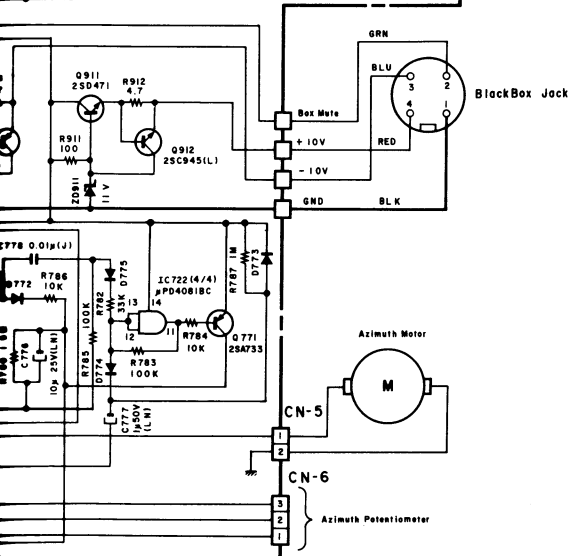
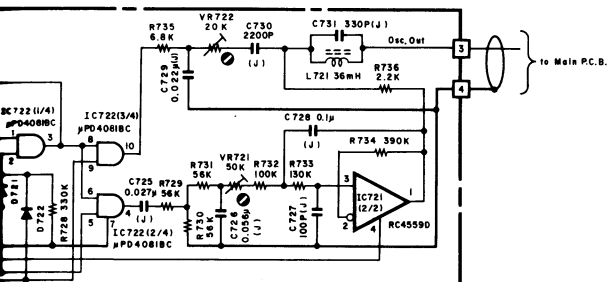
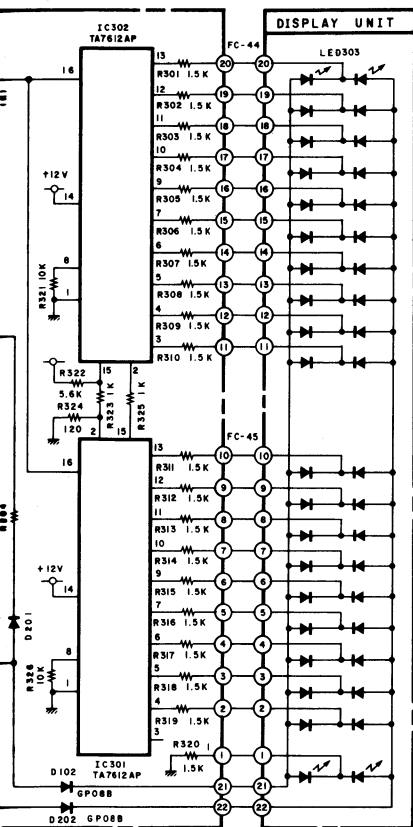

Fig. 7.4

005P, 25A1048 and 25A1175 are interchangeable with each other.
 3365P, 25C2458 and 25C2785 are interchangeable with each other.

Notes: 1. Diode is 1SS53, 1S1555, or 1SS176 unless otherwise specified.
 2. Resistor and capacitor marked with * show typical value.



7.5. Mechanism Control Section

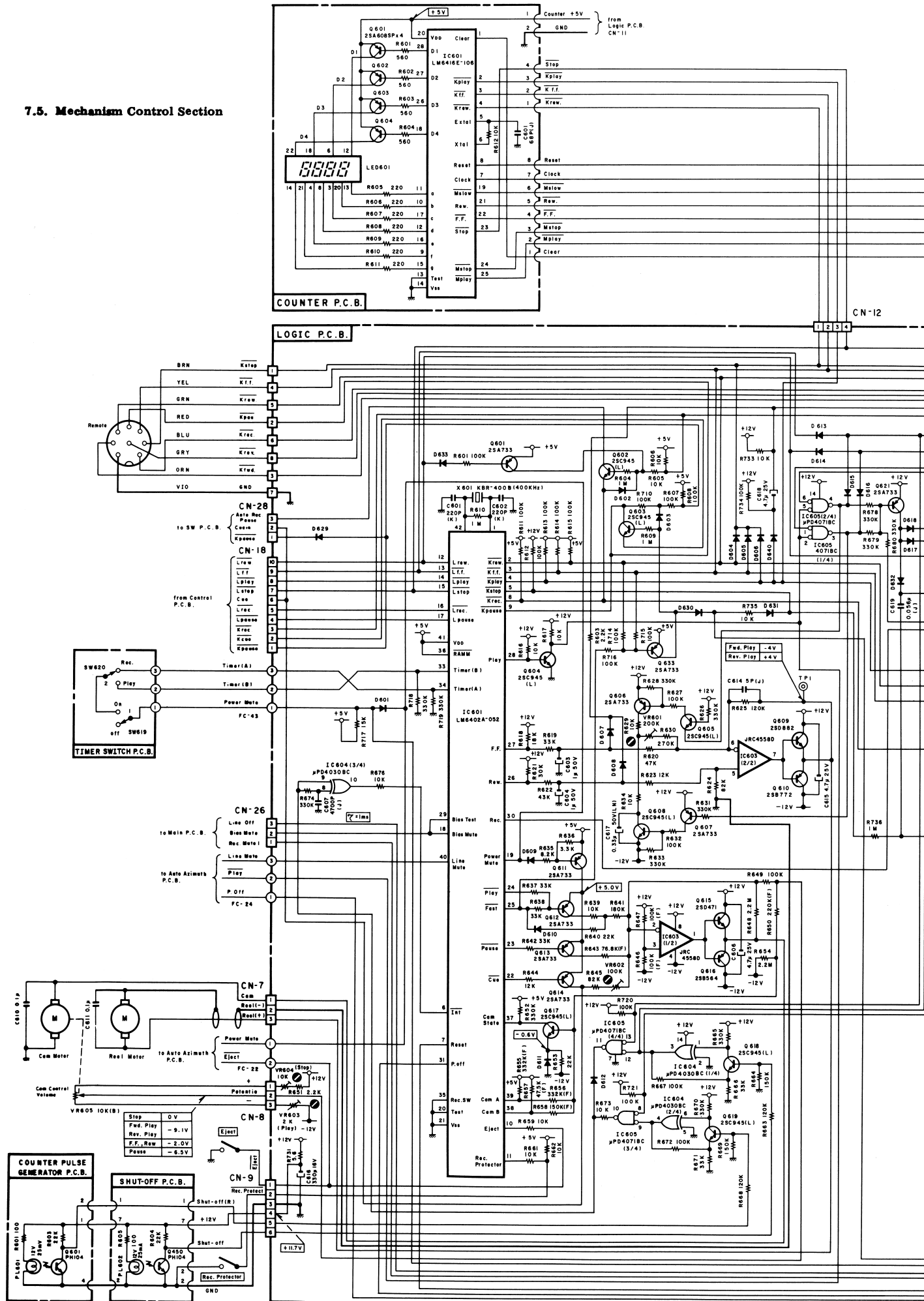

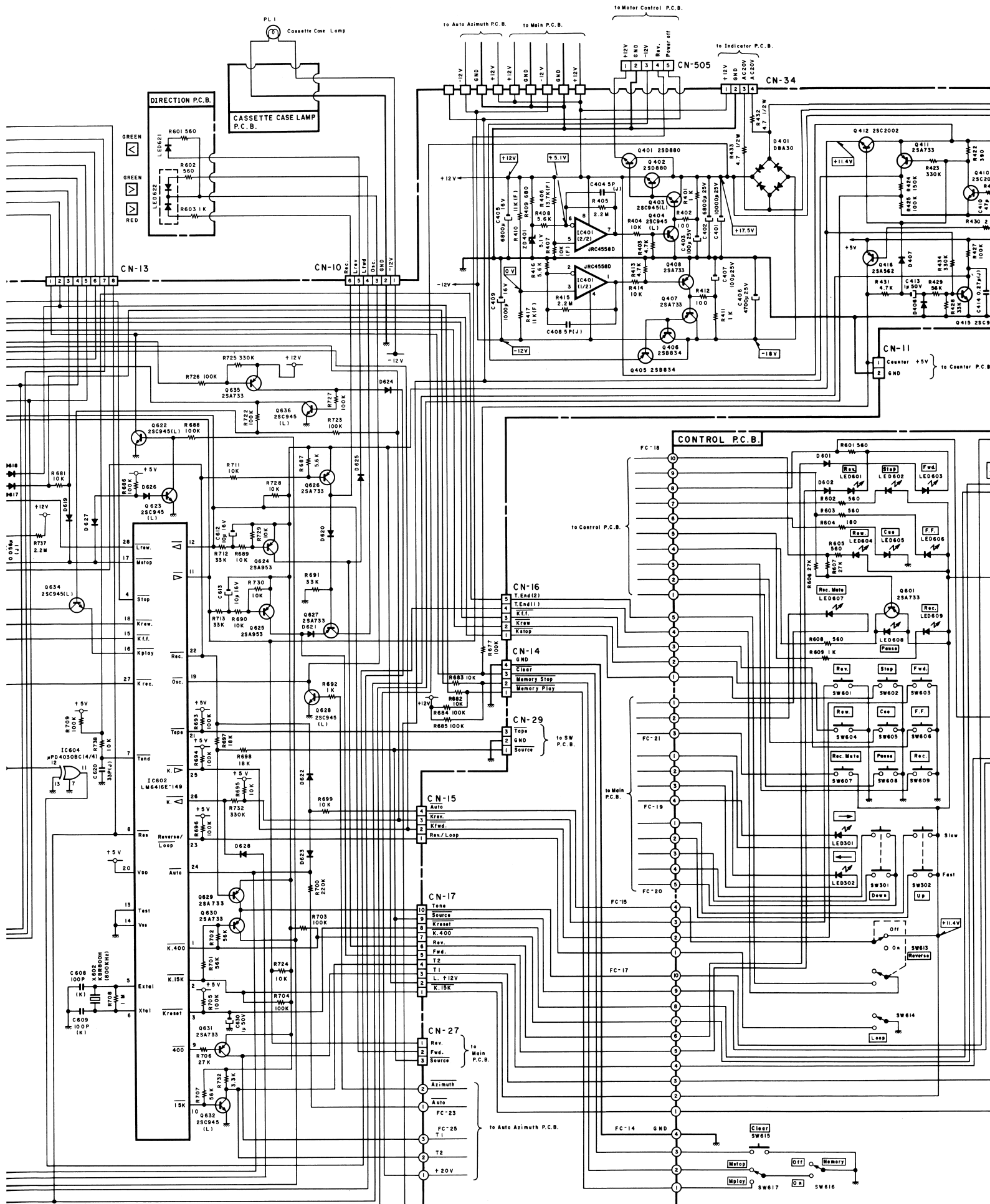
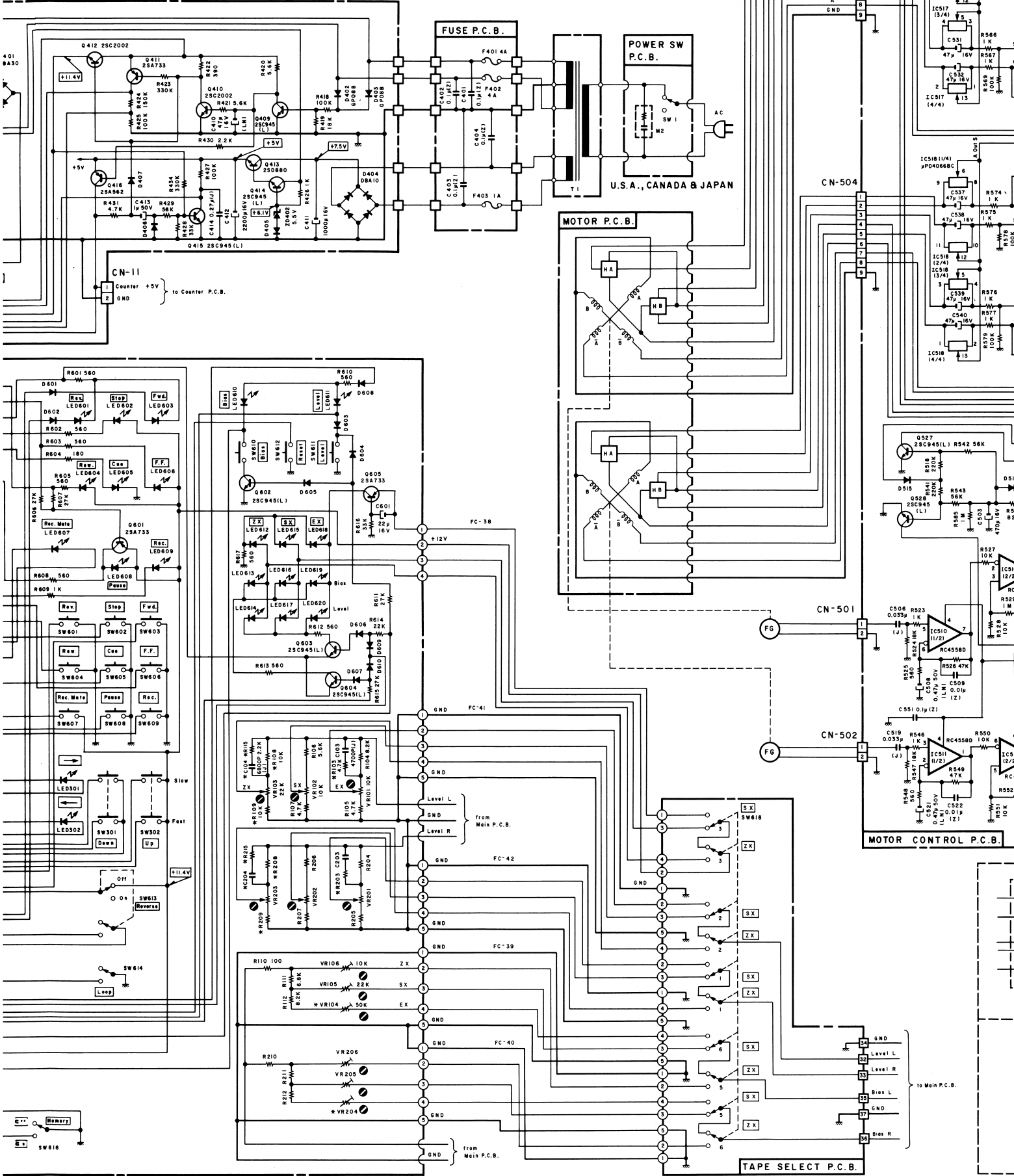

Fig. 7.5

Notes: 1. Diode is 1SS53, 1S1555, or 1SS176 unless otherwise specified.
 2. Resistor and capacitor marked with * show typical value.

Notes: 1. 2SA733, 2SA608SP, 2SA1048 and 2SA1175 are interchangeable with each other.
 2. 2SC945, 2SC536SP, 2SC2458 and 2SC2785 are interchangeable with each other.



otherwise specified.
nominal value.

other.
other.

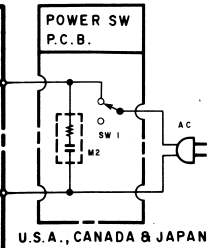

P.C.B.

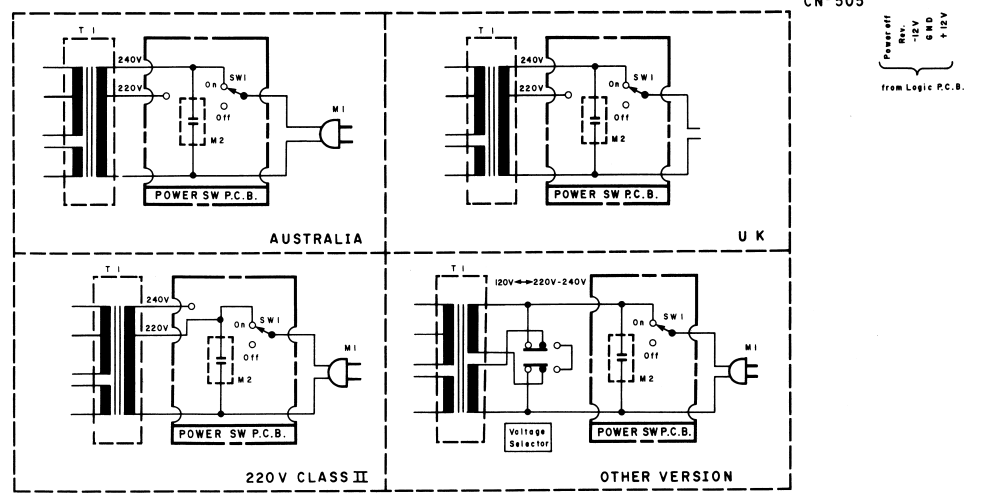
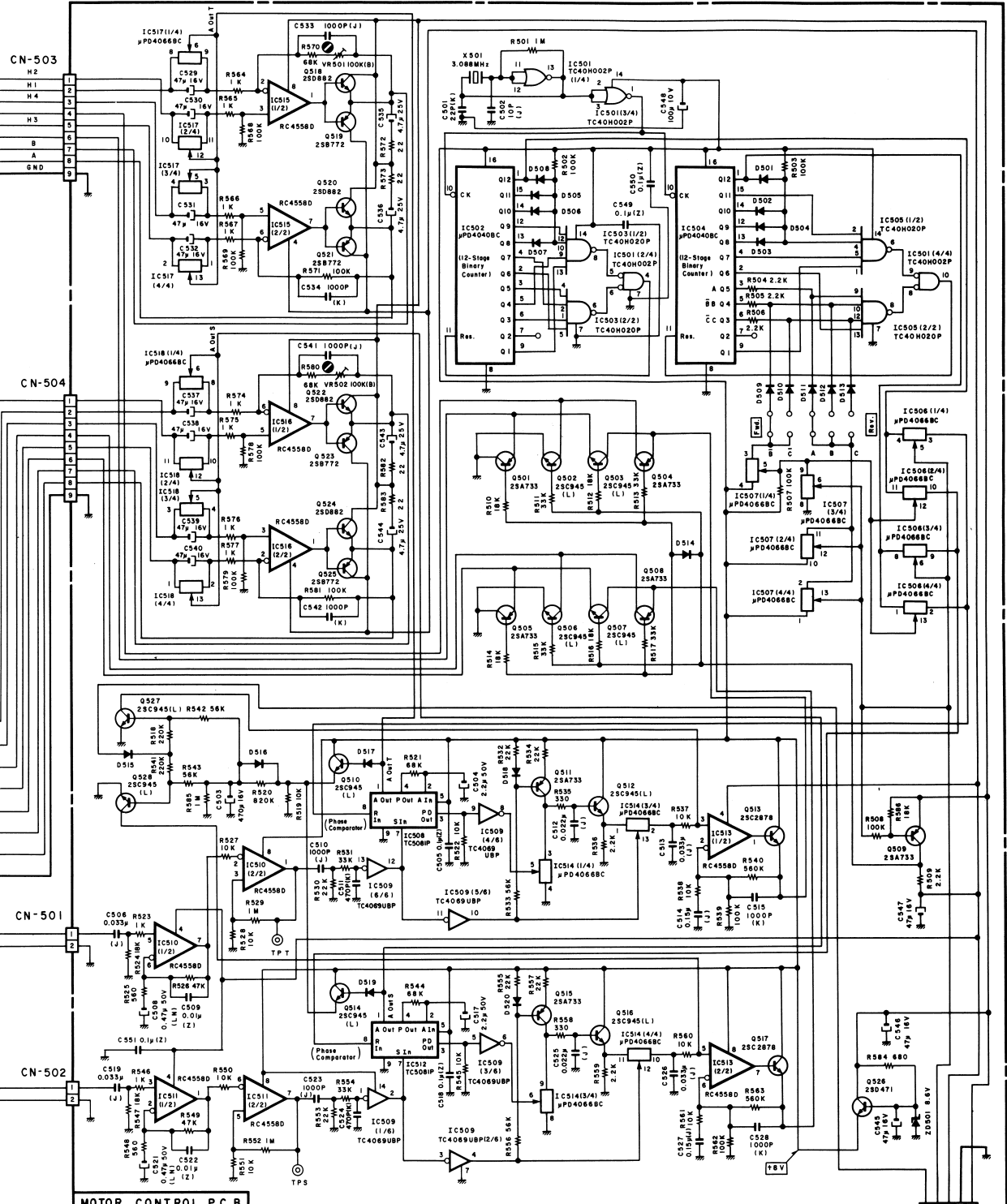
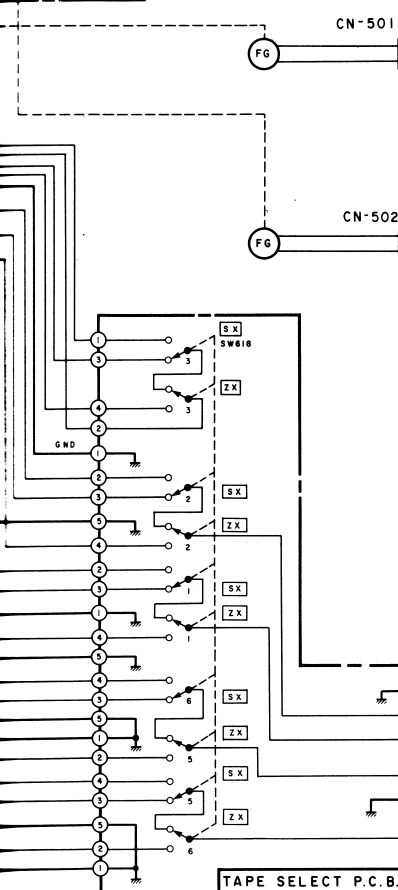
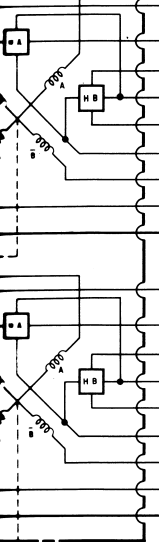

8. WIRING DIAGRAM

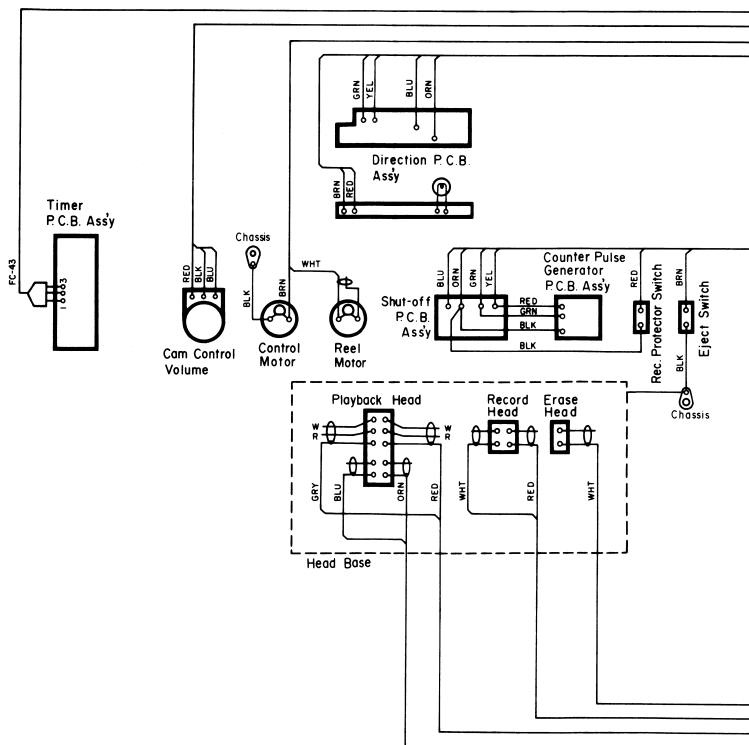
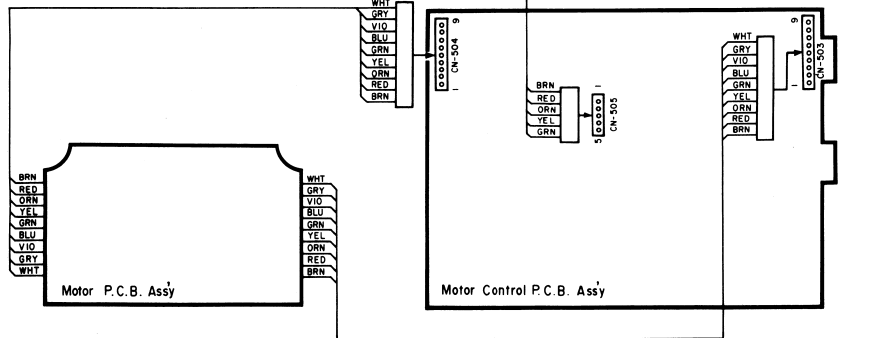
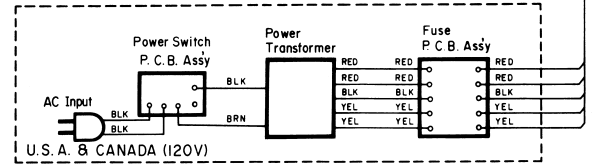
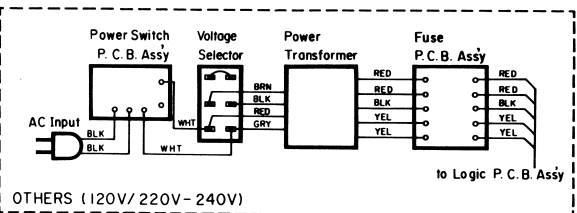
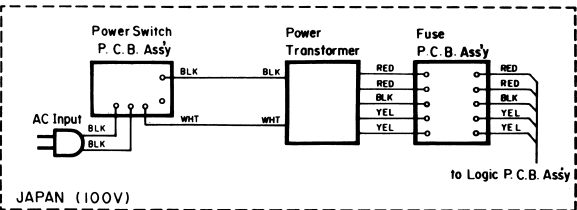
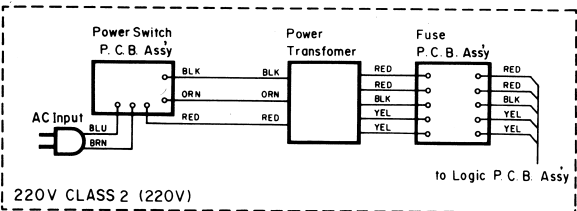
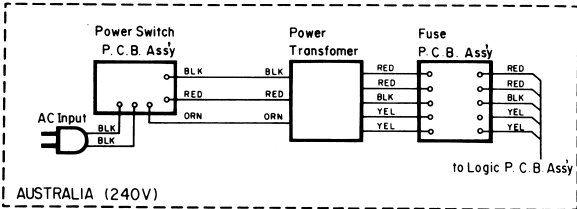
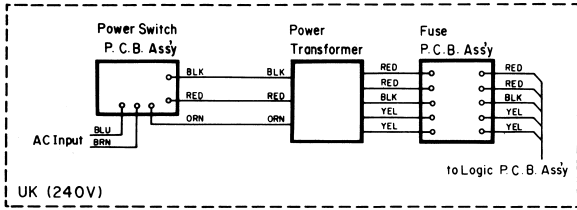

Notes: 1. Table of wire colors

BRN — Brown
 RED — Red
 ORN — Orange
 YEL — Yellow
 GRN — Green
 BLU — Blue
 VIO — Violet
 GRY — Gray
 WHT — White
 BLK — Black

2. Dip side view of the P.C.B. is illustrated.

3. Wire tube color is shown in ().

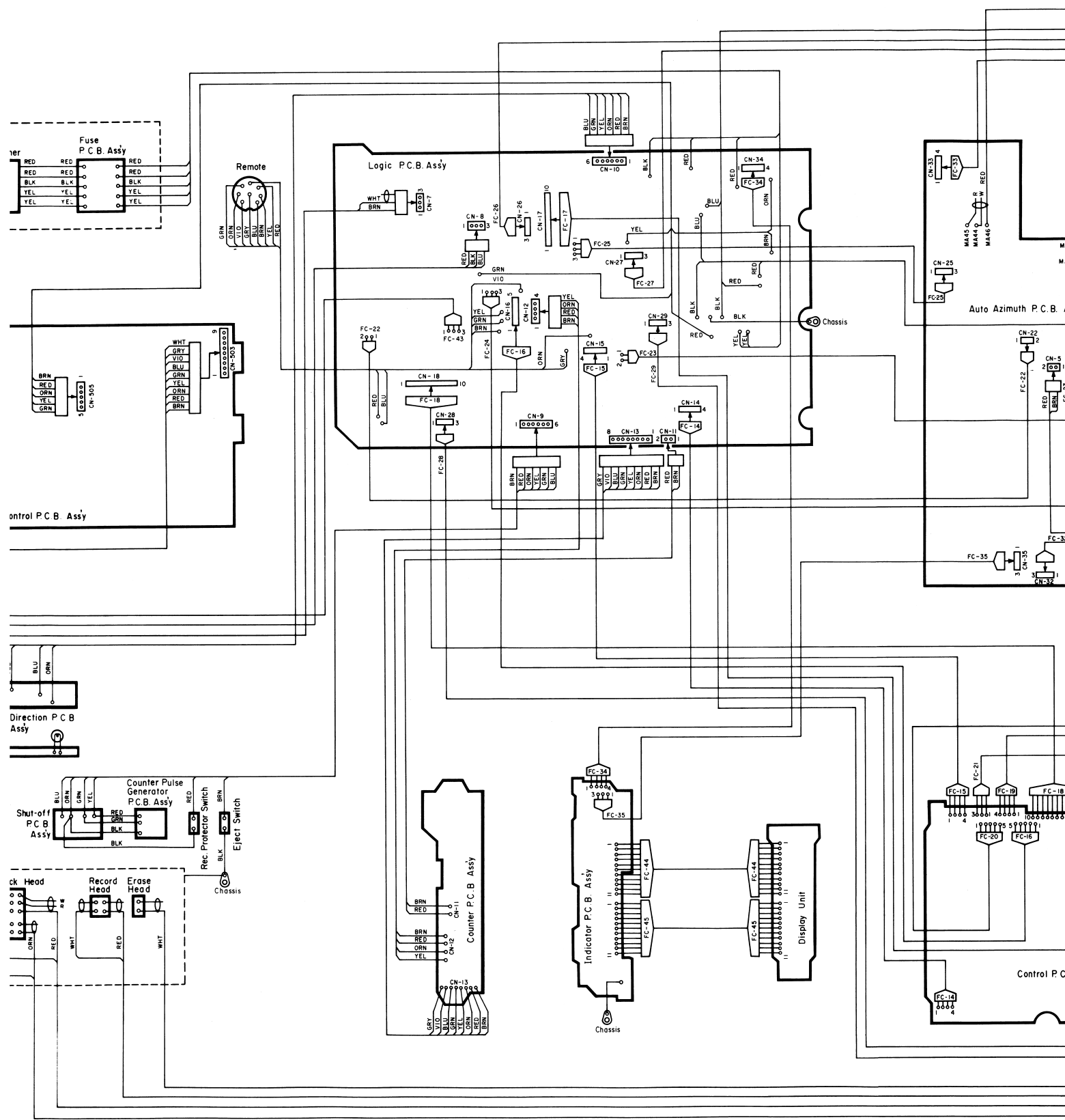

Fig. 8

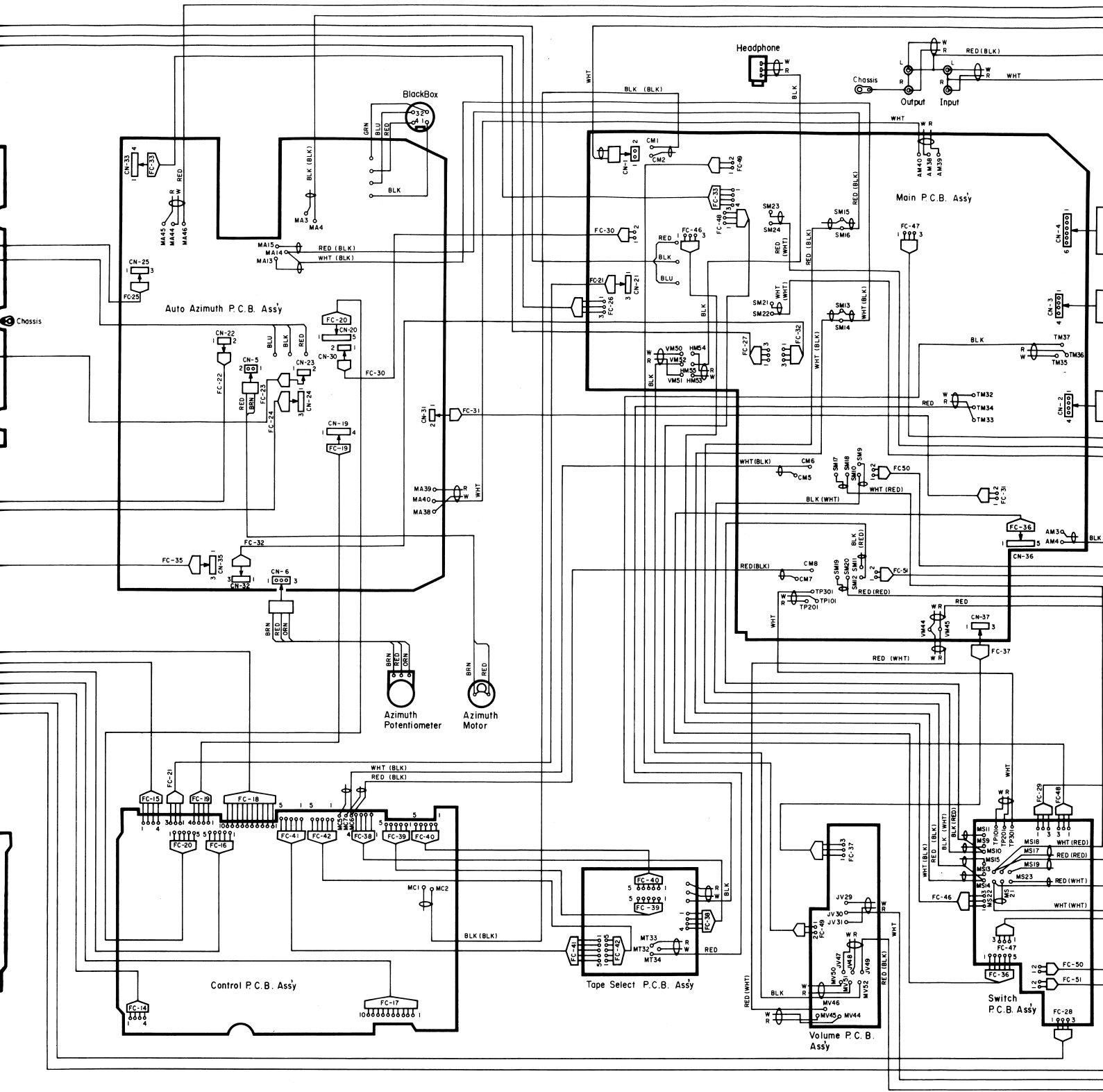

Fig. 8

9. TIMING CHART AND EQ. AMP. FREQUENCY RESPONSE

9.1. Overall Timing Chart

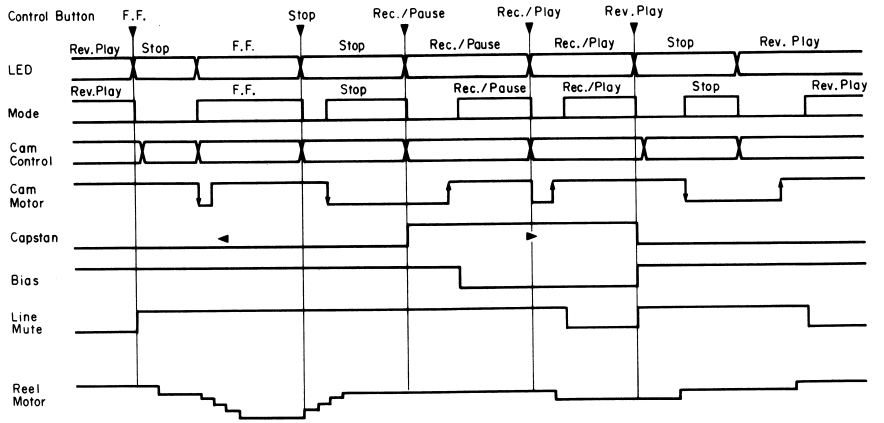

Fig. 9.1

9.2. Eq. Amp. Frequency Response

(1) Playback Frequency Response

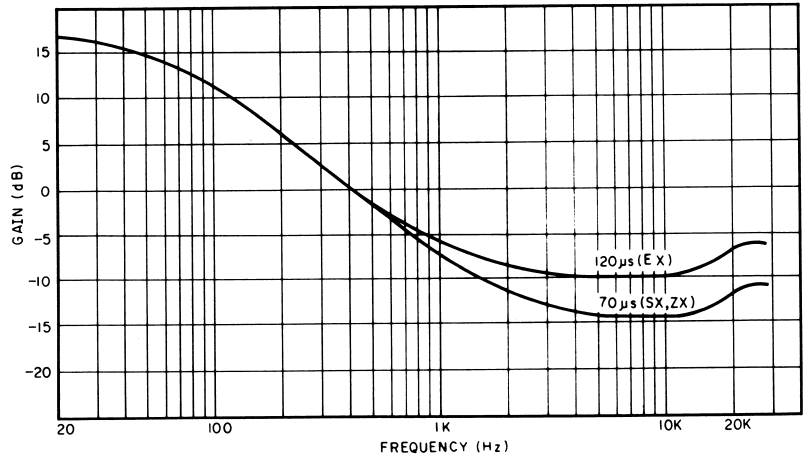

Fig. 9.2.1

(2) Record Current Frequency Response

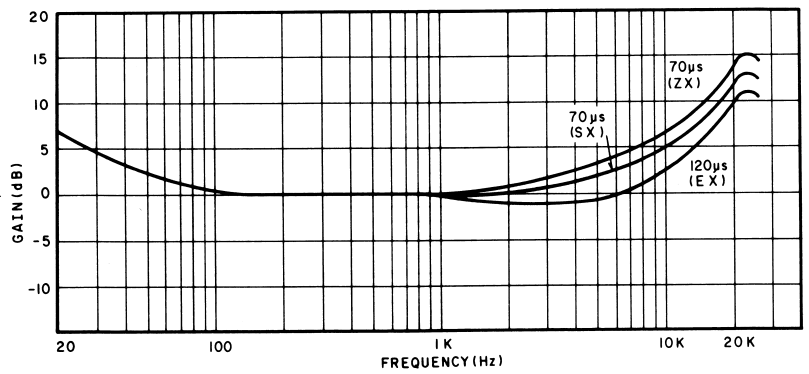
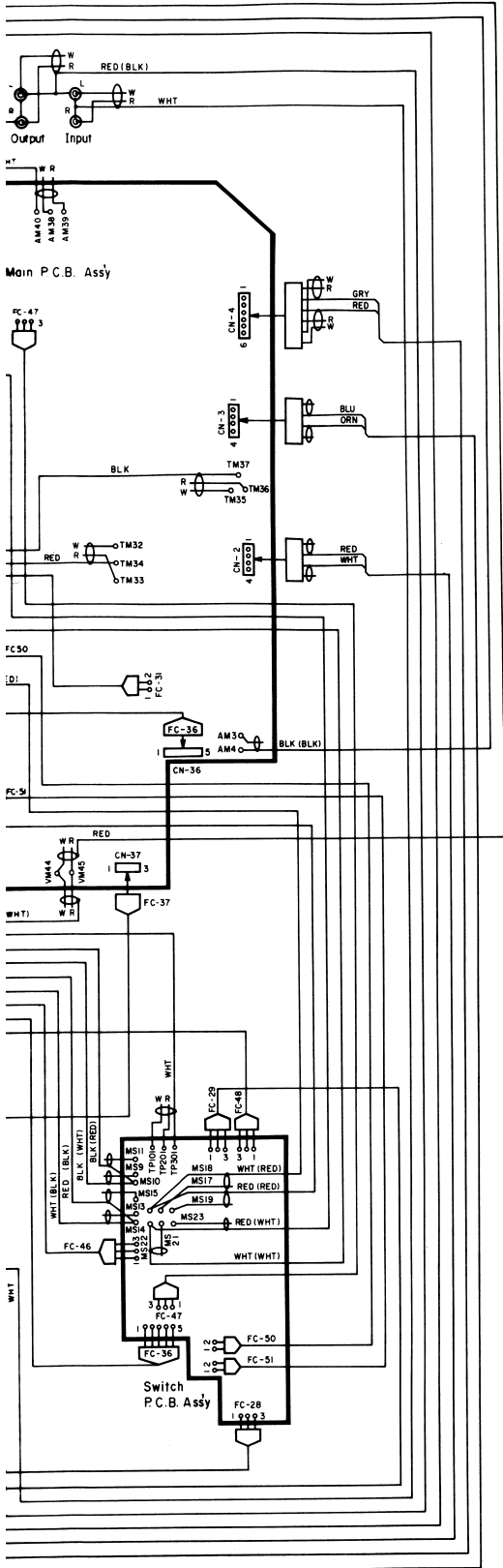

Fig. 9.2.2



10. BLOCK DIAGRAMS

10.1. Amplifier Section

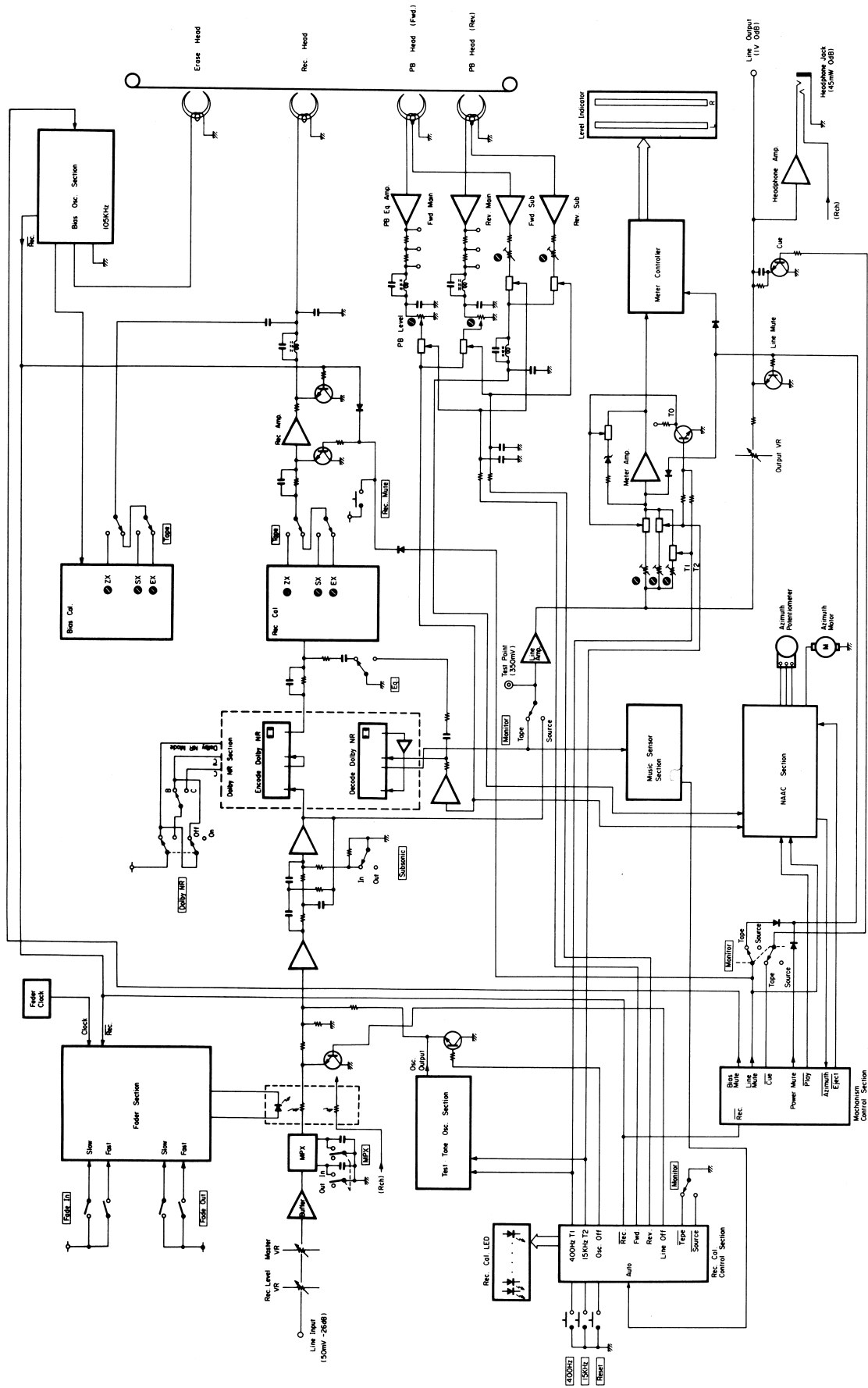

Fig. 10.1

10.2. Mechanism Control Section

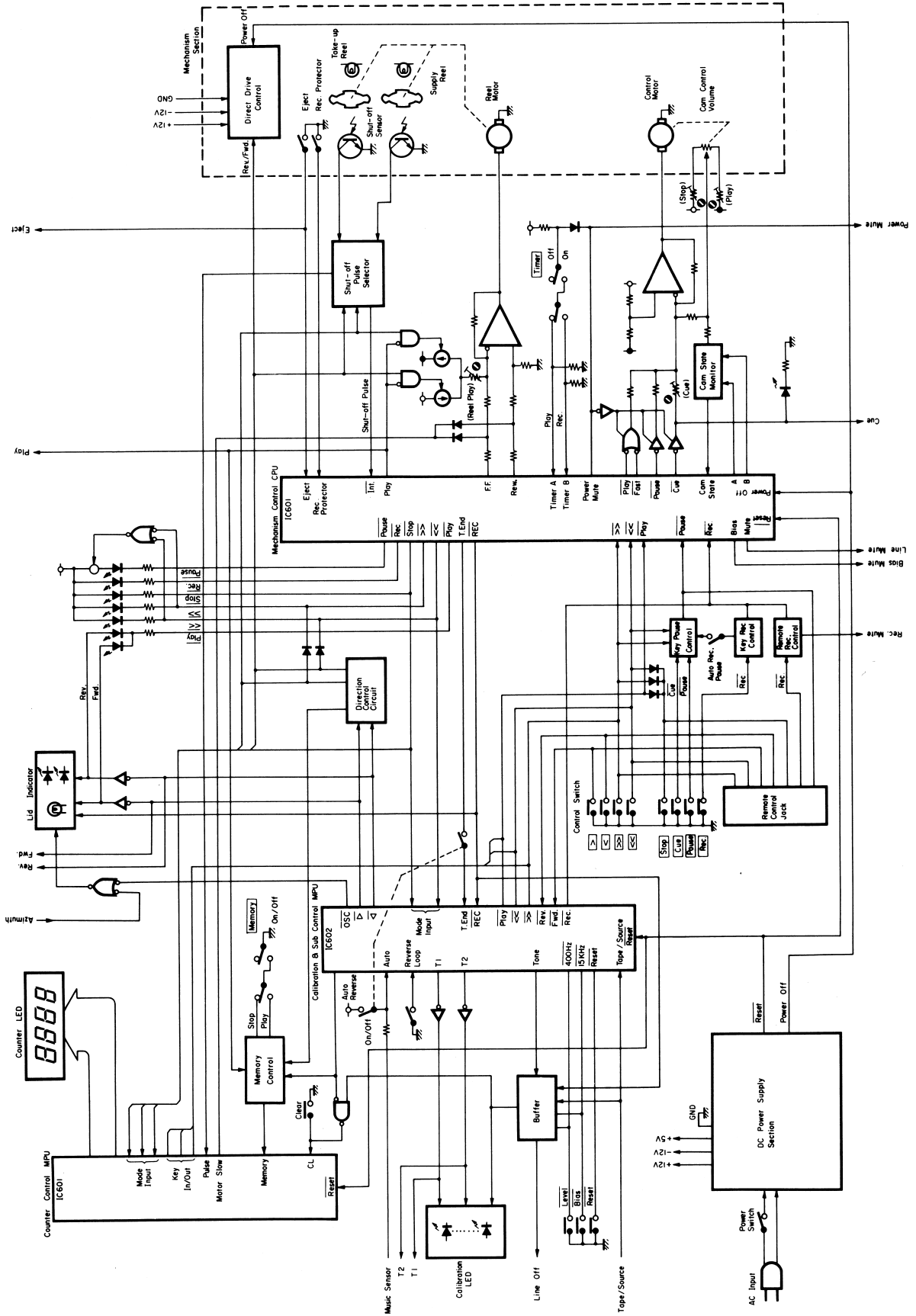

Fig. 10.2

11. SPECIFICATIONS

Track Configuration	4 Tracks/2-Channel Stereo (Playback auto reverse)
Heads	3 (Erase Head x 1, Record Head x 1, 4-Track, 4-Channel Playback Head x 1)
Motors	<ul style="list-style-type: none"> ● TRANSPORT Quartz PLL DC, Brushless, Slotless, Coreless, Super Linear Torque D.D. Motor (Capstan Drive) x 2 DC Motor (Reel Drive x 1) ● AUTO AZIMUTH CORRECTION DC Motor x 1 ● MECHANISM DC Motor x 1
Power Source	100, 120, 120/220-240, 220 or 240 V AC; 50/60 Hz (According to country of sale)
Power Consumption	45 W max.
Tape Speed	1-7/8 ips (4.8 cm/sec.)
Wow and Flutter	Less than 0.019% Wtd rms Less than 0.04% Wtd peak
Frequency Response	20 Hz—22,000 Hz ± 3 dB (recording level -20 dB, ZX Tape) 20 Hz—21,000 Hz ± 3 dB (recording level -20 dB, SX, EXII Tape)
Signal to Noise Ratio	<ul style="list-style-type: none"> Dolby C-Type NR on $<70 \mu s$, ZX Tape Better than 72 dB (400 Hz, 3% THD, IHF A-Wtd rms) Dolby B-Type NR on $<70 \mu s$, ZX Tape Better than 66 dB (400 Hz, 3% THD, IHF A-Wtd rms)
Total Harmonic Distortion	Less than 0.8% (400 Hz, 0 dB, ZX Tape) Less than 1% (400 Hz, 0 dB, SX, EXII Tape)
Erasure	Better than 60 dB (100 Hz, 0 dB)
Separation	Better than 37 dB (1 kHz, 0 dB)
Crosstalk	Better than 60 dB (1 kHz, 0 dB)
Bias Frequency	105 kHz
Input (Line)	50 mV, 50 k ohms
Output (Line)	1 V (400 Hz, 0 dB, Output Level Control at max.) 2.2 k ohms
(Headphones)	45 mV (400 Hz, 0 dB, output level control at max.) 8 ohms
BlackBox Series DC Output	± 10 V, 125 mA max.
Dimensions	450 (W) x 135 (H) x 300 (D) millimeters 17-3/4 (W) x 5-5/16 (H) x 11-13/16 (D) inches
Approximate Weight	9.5 kg 21 lb.

- Specifications and appearance design are subject to change for further improvement without notice.
- Dolby NR under license from Dolby Laboratories Licensing Corporation.
- The word "DOLBY" and the Double-D-Symbol are trademarks of Dolby Laboratories Licensing Corporation.

Service Manual

Nakamichi DRAGON

Nakamichi Corporation

1-153 Suzukicho, Kodaira, Tokyo
Phone: (0423) 42-1111
Telex: 2832610 (NAKAM J)
Cable: NAKAMICHI KOKUBUNJI

Nakamichi U.S.A. Corporation

1101 Colorado Avenue
Santa Monica, Calif. 90401
Phone: (213) 451-5901
Telex: 652429 (NAKREI SNM)

220 Westbury Avenue
Carle Place, N.Y. 11514
Phone: (516) 333-5440